

# PARBO<sup>M.R.</sup>

PARTES PARA SUSPENSION

FOR A SMOOTH RIDE®

CATÁLOGO 109

# CATÁLOGO DE PRODUCTOS

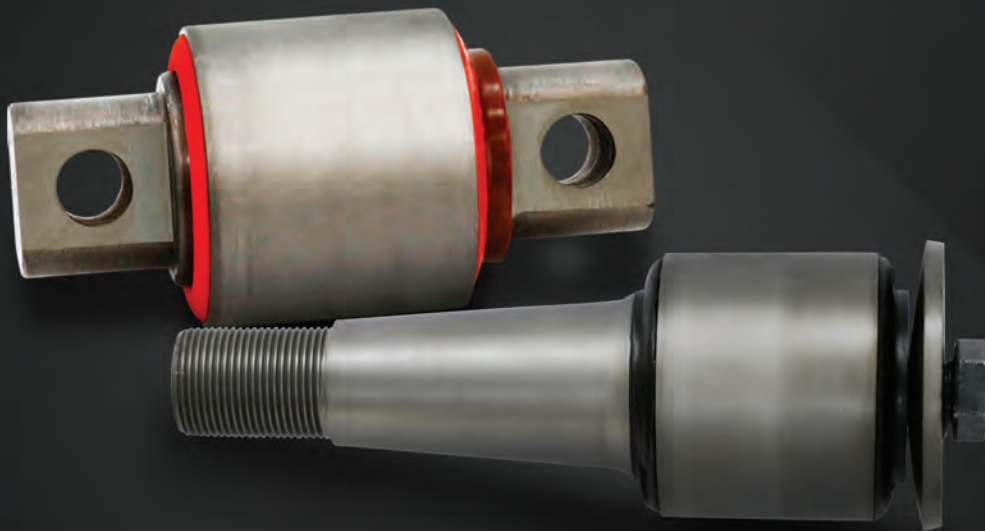

## PARTES PARA SUSPENSIÓN DE EQUIPO PESADO EN HULE Y POLIURETANO

RUBBER AND URETHANE  
HEAVY DUTY SUSPENSION PARTS



NÚCLEOS PARA TENSOR  
TORQUE ROD BUSHINGS

BUJES PARA TENSOR Y MUELLE  
SPRING BUSHINGS

BUJES PARA BALANCÍN  
EQUALIZER BUSHINGS

SOPORTES PARA CABINA  
CAB MOUNTS

SOPORTES PARA MOTOR  
MOTOR MOUNTS

BUJES PARA QUINTA RUEDA  
FIFTH WHEEL BUSHINGS

CODOS Y COPLES  
FLEXIBLES DE ADMISIÓN  
AIR INTAKE RUBBER HOSES AND ELBOWS



CENTRO DE DISTRIBUCIÓN EN ESTADOS UNIDOS / U.S.A. DISTRIBUTION CENTER

Visítenos en / Visit us at [www.parbo.com.mx](http://www.parbo.com.mx)

# PARBO<sup>M.R.</sup>

PARTES PARA SUSPENSION

*FOR A SMOOTH RIDE<sup>®</sup>*

## ABREVIATURAS

<b>A</b>	ALTURA / HEIGHT
<b>D</b>	DIÁMETRO / DIAMETER
<b>DB</b>	DIÁMETRO DE BARRENOS / HOLES DIAMETER
<b>DE</b>	DIÁMETRO EXTERIOR / OUTSIDE DIAMETER
<b>DE</b>	DIÁMETRO DE ENTRADA (EN CODOS Y COPLES) / INTAKE DIAMETER (RUBBER HOSES AND ELBOWS)
<b>DI</b>	DIÁMETRO INTERIOR / INSIDE DIAMETER
<b>DS</b>	DIÁMETRO DE SALIDA (EN CODO Y COPLES) / OUTLET DIAMETER (RUBBER HOSES AND ELBOWS)
<b>HD</b>	DUREZA / HARDNESS
<b>L</b>	LONGITUD / LENGHT
<b>LB</b>	LONGITUD ENTRE BARRENOS / LENGHT BETWEEN HOLES
<b>LC</b>	LONGITUD DEL CASQUILLO / OUTER SLEEVE LENGHT

## FILOSOFÍA | PHILOSOPHY

Ser una empresa líder en el mercado nacional y competitiva a nivel internacional, fabricando productos con calidad de clase mundial, ofreciendo un servicio de excelencia y precio justo para así retribuir equitativamente a nuestros colaboradores y generar una mejor forma de vida.

To be the leader on the domestic market and internationally competitive, manufacturing world class quality products, with excellent service at fair price to fairly reward our associates and generate a better way of life.

## MISIÓN | MISSION

Producir componentes que satisfagan las necesidades del mercado cumpliendo con los estándares de calidad, servicio y precio que éste nos demanda.

Manufacture products to satisfy our market needs meeting quality, service and price standards required.

## VISIÓN | VISION

Lograr el liderazgo en el mercado nacional e incrementar de forma continua nuestra presencia en el mercado internacional mediante la apertura de nuevos mercados, aumentando la participación en los actuales y desarrollando nuevos productos.

Achieve leadership on domestic market and continuously increase international marketshare by opening new markets, growing on current ones and developing new products.

## POLÍTICA DE CALIDAD | QUALITY POLICY

Fabricar componentes para suspensión de equipo pesado y bombas agrícolas con características de clase mundial que cumplan los requisitos de nuestros clientes mediante la mejora continua y la eficacia de los procesos para lograr la satisfacción del usuario.

Manufacture world class quality heavy duty suspension and agricultural pump parts to satisfy our costumers requirements trough continuous improvement and processes effectiveness to achieve user's satisfaction.

## ACLARACIÓN DISCLAIMER

Los nombres y números de referencia de fabricantes en este actálogo son únicamente para ayuda en la identificación de los productos y en ningún momento implican que los productos son de dichos fabricantes. Las dimensiones del producto son las comerciales y pueden variar ligeramente con las reales. Aunque se ha tenido especial cuidado en la veracidad de los datos de este catálogo, Parbo no asume responsabilidad alguna por errores u omisiones.

The name and reference numbers of manufacturers in this catalog are shown only to assist on products identification and under no circumstances does imply that the parts are of those manufacturers. Products dimensions shown are commercial and may slightly vary from the real ones. Although special care has been taken the ensure the accuracy of the data contained on this catalog, Parbo does not assume any liability for errors or omissions.

## LA MADUREZ DEL SISTEMA DE GESTIÓN DE LA CALIDAD

Un Sistema de Gestión de la Calidad orienta a una organización a analizar las necesidades de los clientes, mantener a su personal motivado y preparado, a definir los procesos para la producción y prestación de servicios y mantenerlos bajo un óptimo grado de control.

Cuando un Sistema de Gestión de la Calidad ha ido evolucionando y madurando, ha tenido un desempeño satisfactorio durante varios años, cuando ya ha pasado a través de los procesos de certificación y recertificación, el equipo que conforma la organización certificada va logrando un cambio personal paralelo al del Sistema.

Esta madurez en el Sistema se va logrando a través del compromiso y la labor de todo el personal que lo conforma: el equipo administrativo, el cuerpo de ventas, los operarios; en las distintas áreas y departamentos.

Por medio de la decidida participación de todos los que laboramos en PARBO con respecto al Sistema de Gestión de la Calidad, hay una fuerte consciencia de que siempre hay algo que mejorar, en el producto y en el proceso.

La experiencia del personal de PARBO ha servido para orientar a la organización a la mejora continua y obtener como resultado una actitud de servicio y mejora, detectando puntos claves.

Por medio de la capacitación de todos los integrantes del equipo en PARBO se ha logrado una importante sensibilización, que se traduce en un compromiso real. El equipo operativo y administrativo comprende los costos de la no calidad, por lo tanto orienta su esfuerzo del día a día hacia la mejora continua.

El nivel de madurez del Sistema de Gestión de la Calidad busca evaluar el grado de evolución alcanzado por la institución en el desempeño del mismo. Para evaluar este nivel de madurez se deben tener en cuenta los ocho principios de gestión de la calidad: enfoque al cliente, liderazgo, participación del personal, enfoque basado en procesos, enfoque de sistema para la gestión, mejora continua, enfoque basado en hechos para la toma de decisiones y relaciones mutuamente beneficiosas con clientes y proveedores.

La empresa reconoce de la manera más amplia, que los logros obtenidos gracias al Sistema de Gestión de la Calidad se deben al compromiso, dedicación y entrega de todos y cada uno de los integrantes de la misma.



## **THE MATURITY OF A QUALITY MANAGEMENT SYSTEM**

A Quality Management System leads an organization to analyze the customer needs, to keep its members motivated and trained, to define processes for production and for service and to keep them under an optimum state of control.

When a Quality Management System has been evolving and maturing, when it has been having a satisfactory performance for several years, when it has been going through the certification and recertification processes, then the team of members of the certified organization gets a personal change parallel to the System.

This mature state in the System is being obtained through compromise and hard work from all members: management team, sales personnel, and working force; from different areas and departments.

It is through a devoted work from all of us whom work in PARBO pertaining to the Quality Management System, that there is a strong conscience that there will always be something to improve, both in the product and the process.

It is the experience of PARBO's team which has been useful to lead the organization towards continuous improvement to get as a result an attitude of improvement and service, finding critical issues.

PARBO's team has achieved through training an important degree of sensibility, which turns into a real commitment. The management and operative teams understand the costs of poor quality; therefore they lead their daily efforts towards continuous improvement.

The maturity degree in Quality Management System looks forward to evaluate the evolution level reached by the organization in its performance. To evaluate this maturity level it must take in account the eight principles of Quality Management: Customer focus, Leadership, Involvement of people, Process approach, System approach to management, Continuous improvement, Factual approach to decision-making, Mutually beneficial supplier and customer relationships.

PARBO recognizes in a wide sense that the results achieved through the Quality Management System are due to the commitment, dedication and hard work from each and every one of the members of the Company.



# ÍNDICE INDEX

<b>NÚCLEOS PARA TENSOR</b> TORQUE ROD BUSHINGS	<b>07</b>
<b>BUJES CENTRAL, LATERAL Y PARA MUELLE</b> SPRING, BEAM END, CENTER AND EQUALIZER BUSHINGS	<b>15</b>
<b>BUJES PARA SUSPENSIÓN</b> SUSPENSION BUSHINGS	<b>20</b>
<b>BUJES PARA BARRA DE TORSIÓN</b> STABILIZER BAR BUSHINGS	<b>21</b>
<b>SOPORTES PARA SUSPENSIÓN</b> INSULATOR PADS	<b>23</b>
<b>GANCHOS Y GUÍAS PARA COFRE</b> HOOD PINS AND HOOKS	<b>43</b>
<b>SOPORTES PARA CABINA</b> CAB MOUNTS	<b>44</b>
<b>SOPORTES PARA MOTOR</b> MOTOR MOUNTS	<b>49</b>
<b>BUJES PARA QUINTA RUEDA</b> FIFTH WHEEL BUSHINGS	<b>57</b>
<b>BUJES PARA SUSPENSIÓN DE TRAILER</b> EQUALIZER AND TORQUE ROD BUSHINGS	<b>61</b>
<b>BUJES PARA MUELLE</b> SPRING BUSHINGS	<b>70</b>
<b>CORBATAS, CODOS Y COPLES FLEXIBLES DE ADMISIÓN</b> AIR INTAKE RUBBER HOSES AND ELBOWS	<b>81</b>

# NÚCLEOS PARA TENSOR

TORQUE ROD  
BUSHINGS

**PARBO**<sup>M.R.</sup>  
PARTES PARA SUSPENSION  
*PARA UN MANEJO SUAVE*













<p><b>NÚCLEO PARA TENSOR 2''</b> TORQUE ROD BUSHING</p> <p><b>200-447691</b> OEM 47691</p> 	<p><b>NÚCLEO PARA TENSOR 2''</b> TORQUE ROD BUSHING</p> <p><b>200-447691S</b> OEM 47691-S</p> 	<p><b>NÚCLEO PARA TENSOR 2'' POLIURETANO</b> URETHANE TORQUE ROD BUSHING</p> <p><b>200-447691P</b> OEM 47691</p> 
<p>SUSPENSION: HENDRICKSON E4-360, E4-400, HA-360, HA-400, FREIGHTLINER</p> <p><b>ESPECIFICACIONES</b> D= 2'' DB= 21/32'' LB= 4 3/8''</p>	<p>SUSPENSION: HENDRICKSON E4-360, E4-400, HA-360, HA-400, FREIGHTLINER</p> <p><b>ESPECIFICACIONES</b> D= 2'' DB1= 21/32'' DB2= 29/64'' LB= 4 3/8''</p>	<p>SUSPENSION: HENDRICKSON E4-360, E4-400, HA-360, HA-400, FREIGHTLINER</p> <p><b>ESPECIFICACIONES</b> D= 2'' DB= 21/32'' LB= 4 3/8'' HD= 80</p>

<p><b>NÚCLEO PARA TENSOR 2'' POLIURETANO</b> URETHANE TORQUE ROD BUSHING</p> <p><b>200-447691SP</b> OEM 47691-S</p> 	<p><b>NÚCLEO PARA TENSOR 2''</b> TORQUE ROD BUSHING</p> <p><b>200-447691C</b> OEM 447691</p> 	<p><b>NÚCLEO PARA TENSOR 2'' POLIURETANO</b> URETHANE TORQUE ROD BUSHING</p> <p><b>200-447691CP</b> OEM 447691</p> 
<p>SUSPENSION: HENDRICKSON E4-360, E4-400, HA-360, HA-400, FREIGHTLINER</p> <p><b>ESPECIFICACIONES</b> D= 2'' DB1= 21/32'' DB2= 29/64'' LB= 4 3/8'' HD= 80</p>	<p>SUSPENSION: HENDRICKSON E4-360, E4-400, HA-360, HA-400, FREIGHTLINER</p> <p><b>ESPECIFICACIONES</b> DE= 1 29/32'' DB= 21/32'' LB= 4 3/8''</p>	<p>SUSPENSION: HENDRICKSON E4-360, E4-400, HA-360, HA-400, FREIGHTLINER</p> <p><b>ESPECIFICACIONES</b> DE= 1 29/32'' DB= 21/32'' LB= 4 3/8'' HD= 80</p>

<p><b>NÚCLEO PARA TENSOR 2 3/8''</b> TORQUE ROD BUSHING</p> <p><b>200-6582</b> OEM IPC-233291</p> 	<p><b>NÚCLEO PARA TENSOR 2 15/32''</b> TORQUE ROD BUSHING</p> <p><b>200-57256</b> OEM 57256</p> 	<p><b>NÚCLEO PARA TENSOR 2 15/32'' POLIURETANO</b> URETHANE TORQUE ROD BUSHING</p> <p><b>200-57256P</b> OEM 57256</p> 
<p>SUSPENSION: FREIGHTLINER FH-34, DINA</p> <p><b>ESPECIFICACIONES</b> D= 2 3/8'' DB= 21/32'' LB= 4 3/8''</p>	<p>SUSPENSION: HENDRICKSON HA, HAS 360/400/460, KENWORTH 2000, INTERNATIONAL/NAVISTAR 8100/9200</p> <p><b>ESPECIFICACIONES</b> D= 2 15/32'' DB= 21/32'' LB= 4 3/8''</p>	<p>SUSPENSION: HENDRICKSON HA, HAS 360/400/460, KENWORTH 2000, INTERNATIONAL/NAVISTAR 8100/9200</p> <p><b>ESPECIFICACIONES</b> D= 2 15/32'' DB= 21/32'' LB= 4 3/8'' HD= 80</p>

<p><b>NÚCLEO PARA TENSOR 2 17/32''</b> TORQUE ROD BUSHING</p> <p><b>200-44694</b> OEM 44694, RB-164</p> 	<p><b>NÚCLEO PARA TENSOR 2 17/32'' ALTO CONFINAMIENTO, POLIURETANO</b> TORQUE ROD BUSHING</p> <p><b>200-44694HC</b> OEM 44694, RB-259</p> 	<p><b>NÚCLEO PARA TENSOR 2 17/32'' POLIURETANO</b> URETHANE TORQUE ROD BUSHING</p> <p><b>200-44694P</b> OEM 44694, RB-164</p> 
<p>SUSPENSION: HENDRICKSON 380/440, KENWORTH GLIDE RIDE, PETERBILT AIR LEAF, VOLVO AIR RIDE, MACK ST34, INTERNATIONAL/NAVISTAR 8100/9200</p> <p><b>ESPECIFICACIONES</b> D= 2 17/32'' DB= 21/32'' LB= 4 3/8''</p>	<p>SUSPENSION: HENDRICKSON 380/440, KENWORTH GLIDE RIDE, PETERBILT AIR LEAF, VOLVO AIR RIDE, MACK ST34, INTERNATIONAL/NAVISTAR 8100/9200</p> <p><b>ESPECIFICACIONES</b> D= 2 17/32'' DB= 21/32'' LB= 4 3/8''</p>	<p>SUSPENSION: HENDRICKSON 380/440, KENWORTH GLIDE RIDE, PETERBILT AIR LEAF, VOLVO AIR RIDE, MACK ST34, INTERNATIONAL/NAVISTAR 8100/9200</p> <p><b>ESPECIFICACIONES</b> D= 2 17/32'' DB= 21/32'' LB= 4 3/8'' HD= 80</p>













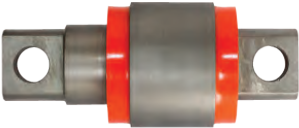

<p><b>NÚCLEO PARA TENSOR 2 11/16"</b> TORQUE ROD BUSHING</p> <p><b>200-1460</b> OEM KO66-342</p> 	<p><b>NÚCLEO PARA TENSOR 2 11/16" POLIURETANO</b> URETHANE TORQUE ROD BUSHING</p> <p><b>200-1460P</b> OEM KO66-342</p> 	<p><b>NÚCLEO PARA TENSOR 2 7/8" USO EXTREMO POLIURETANO</b> URETHANE TORQUE ROD BUSHING</p> <p><b>200-1460PX</b> OEM KO66-342</p> 
<p>SUSPENSIÓN: KENWORTH T-800</p> <p>ESPECIFICACIONES D= 2 11/16" DB= 21/32" LB= 4 3/8"</p>	<p>SUSPENSIÓN: KENWORTH T-800</p> <p>ESPECIFICACIONES D= 2 11/16" DB= 21/32" LB= 4 3/8" HD= 80</p>	<p>SUSPENSIÓN: KENWORTH T-800</p> <p>ESPECIFICACIONES D= 2 7/8" DB= 21/32" LB= 4 3/8" HD= 80</p>
<p><b>BUJE PARA TENSOR KW T-800 POLIURETANO</b> URETHANE TORQUE ROD BUSHING</p> <p><b>200-66342P</b> OEM KO66-342</p> 	<p><b>PERNO PARA BUJE DE TENSOR T-800</b> TORQUE ROD PIN</p> <p><b>200-1460R</b> OEM K179-384</p> 	<p><b>PERNO PARA BUJE DE TENSOR</b> TORQUE ROD PIN</p> <p><b>200-119448</b> OEM 119448</p> 
<p>SUSPENSIÓN: KENWORTH T-800</p> <p>ESPECIFICACIONES DE= 2 25/32" DI= 1 3/4" L= 2 5/8"</p>	<p>SUSPENSIÓN: KENWORTH T-800</p> <p>ESPECIFICACIONES DE= 1 3/4" DB= 21/32" LB= 4 3/8"</p>	<p>SUSPENSIÓN: FREIGHTLINER FH32,36</p> <p>ESPECIFICACIONES DE= 1 5/16" DB= 21/32" LB= 4 3/8"</p>
<p><b>BUJE PARA TENSOR DE POLIURETANO</b> URETHANE TORQUE ROD BUSHING</p> <p><b>200-119569P</b> OEM 119569</p> 	<p><b>NÚCLEO PARA TENSOR 2 3/4"</b> TORQUE ROD BUSHING</p> <p><b>200-44695</b> OEM 44695</p> 	<p><b>NÚCLEO PARA TENSOR 2 3/4" ALTO CONFINAMIENTO</b> HIGH CONFINEMENT TORQUE ROD BUSHING</p> <p><b>200-44695HC</b> OEM</p> 
<p>SUSPENSIÓN: FREIGHTLINER FH32,36</p> <p>ESPECIFICACIONES DE= 2 3/8" DI= 1 5/16" L= 2 1/8"</p>	<p>SUSPENSIÓN: HENDRICKSON HA, HAS AIR SUSPENSIONS, KENWORTH AIR GLIDE 100, BIG SIX, MACK CAMELBACK, INTERNATIONAL/NAVISTAR 8100/9200</p> <p>ESPECIFICACIONES DE= 2 3/4" DB= 21/32" LB= 4 3/8"</p>	<p>SUSPENSIÓN: HENDRICKSON HA, HAS AIR SUSPENSIONS, KENWORTH AIR GLIDE 100, BIG SIX, MACK CAMELBACK, INTERNATIONAL/NAVISTAR 8100/9200</p> <p>ESPECIFICACIONES DE= 2 3/4" DB= 21/32" LB= 4 3/8"</p>
<p><b>NÚCLEO PARA TENSOR 2 3/4" POLIURETANO</b> URETHANE TORQUE ROD BUSHING</p> <p><b>200-44695P</b> OEM 44695</p> 	<p><b>NÚCLEO PARA TENSOR 2 3/4" ALTO CONFINAMIENTO, POLIURETANO</b> HIGH CONFINEMENT URETHANE TORQUE ROD BUSHING</p> <p><b>200-44695HCP</b> OEM</p> 	<p><b>BUJE PARA TENSOR DE 2 3/4" SIN CASQUILLO</b> TORQUE ROD BUSHING</p> <p><b>200-64400</b> OEM 64400</p> 
<p>SUSPENSIÓN: HENDRICKSON HA, HAS AIR SUSPENSIONS, KENWORTH AIR GLIDE 100, BIG SIX, MACK CAMELBACK, INTERNATIONAL/NAVISTAR 8100/9200</p> <p>ESPECIFICACIONES DE= 2 3/4" DB= 21/32" LB= 4 3/8" HD= 80</p>	<p>SUSPENSIÓN: HENDRICKSON HA, HAS AIR SUSPENSIONS, KENWORTH AIR GLIDE 100, BIG SIX, MACK CAMELBACK, INTERNATIONAL/NAVISTAR 8100/9200</p> <p>ESPECIFICACIONES DE= 2 3/4" DB= 21/32" LB= 4 3/8" HD= 80</p>	<p>SUSPENSIÓN: HENDRICKSON</p> <p>ESPECIFICACIONES DE= 3 1/4" LB= 4 3/8" DB= 5/8"</p>

<b>BUJE PARA TENSOR DE 2 3/4" SIN CASQUILLO POLIURETANO</b> URETHANE TORQUE ROD BUSHING	<b>NÚCLEO PARA TENSOR 2 3/4"</b> TORQUE ROD BUSHING	<b>NÚCLEO PARA TENSOR</b> TORQUE ROD BUSHING
<b>200-64400P</b> OEM 64400	<b>200-010</b> OEM 49210	<b>200-836940</b> OEM 836940
		
SUSPENSIÓN: HENDRICKSON	SUSPENSIÓN: HENDRICKSON SERIES 340-520, PETERBILT AIRTRAC	SUSPENSIÓN: KENWORTH AIR GLIDE
<b>ESPECIFICACIONES</b> DE= 3 1/4" LB= 4 3/8" DB= 5/8" HD= 80	<b>ESPECIFICACIONES</b> DE= 2 3/4" DB= 25/32" LB= 4 3/8"	<b>ESPECIFICACIONES</b> DE= 2 3/4" DB= 23/32" LB= 4 3/8"

<b>NÚCLEO PARA TENSOR POLIURETANO</b> URETHANE TORQUE ROD BUSHING	<b>NÚCLEO PARA TENSOR</b> TORQUE ROD BUSHING	<b>NÚCLEO PARA TENSOR POLIURETANO</b> URETHANE TORQUE ROD BUSHING
<b>200-836940P</b> OEM 836940	<b>200-588118C92</b> OEM 588118C92	<b>200-588118C92P</b> OEM 588118C92
		
SUSPENSIÓN: KENWORTH AIR GLIDE	SUSPENSIÓN: INTERNATIONAL/NAVISTAR 9600, 9700	SUSPENSIÓN: INTERNATIONAL/NAVISTAR 9600, 9700
<b>ESPECIFICACIONES</b> DE= 2 3/4" DB= 23/32" LB= 4 3/8" HD= 80	<b>ESPECIFICACIONES</b> DE= 1 7/8" DB= 21/32" LB= 4 3/8"	<b>ESPECIFICACIONES</b> DE= 1 7/8" DB= 21/32" LB= 4 3/8" HD= 80

<b>NÚCLEO PARA TENSOR</b> TORQUE ROD BUSHING	<b>NÚCLEO PARA TENSOR POLIURETANO</b> URETHANE TORQUE ROD BUSHING	<b>NÚCLEO PARA TENSOR FAMSA</b> TORQUE ROD BUSHING
<b>200-1479</b> OEM 932420	<b>200-1479P</b> OEM 932420	<b>200-1480</b> OEM 32174-000
		
SUSPENSIÓN: KENWORTH BIG SIX	SUSPENSIÓN: KENWORTH BIG SIX	SUSPENSIÓN: HENDRICKSON, FAMSA
<b>ESPECIFICACIONES</b> DE= 3 1/2" DB= 21/32" LB= 4 3/8" LC= 2 3/4	<b>ESPECIFICACIONES</b> DE= 3 1/2" DB= 21/32" LB= 4 3/8" LC= 2 3/4 HD= 80	<b>ESPECIFICACIONES</b> D= 3 17/32" DB= 21/32" LB= 4 3/8"

<b>NÚCLEO PARA TENSOR FAMSA POLIURETANO</b> URETHANE TORQUE ROD BUSHING	<b>NÚCLEO PARA TENSOR</b> TORQUE ROD BUSHING	<b>NÚCLEO PARA TENSOR</b> TORQUE ROD BUSHING
<b>200-1480P</b> OEM 32174-000	<b>200-1396</b> OEM	<b>200-1397</b> OEM A-2297-K-1052
		
SUSPENSIÓN: HENDRICKSON, FAMSA	SUSPENSIÓN: KENWORTH ROCKWELL	SUSPENSIÓN: KENWORTH BIG SIX
<b>ESPECIFICACIONES</b> D= 3 17/32" DB= 21/32" LB= 4 3/8" HD= 80	<b>ESPECIFICACIONES</b> DE= 3 1/2" DB= 29/32" LB= 5 1/4"	<b>ESPECIFICACIONES</b> DE= 4 1/8" DB= 21/32" LB= 4 3/8" LC= 2 1/2"













<p><b>NÚCLEO PARA TENSOR</b> TORQUE ROD BUSHING</p> <p><b>200-1398</b></p> <p>OEM A-2297-K-1051</p> 	<p><b>NÚCLEO PARA TENSOR</b> TORQUE ROD BUSHING</p> <p><b>200-1399</b></p> <p>OEM A-2297-X-3664</p> 	<p><b>BUJE PARA TENSOR</b> TORQUE ROD BUSHING</p> <p><b>200-47244</b></p> <p>OEM A-2297-J-1050</p> 
<p>SUSPENSIÓN: KENWORTH BIG SIX, ROCKWELL</p> <p>ESPECIFICACIONES DE= 4 1/8" DB= 29/32" LB= 5 1/4" LC= 2 1/2"</p>	<p>SUSPENSIÓN: ROCKWELL</p> <p>ESPECIFICACIONES DE= 4 1/8" DB= 1 1/32" LB= 5 1/4" LC= 2 1/2"</p>	<p>SUSPENSIÓN: KENWORTH BIG SIX, ROCKWELL</p> <p>ESPECIFICACIONES DE= 4 1/8" DI= 2 3/16" DI2= 1 3/4" L= 3 15/32"</p>
<p><b>NÚCLEO EXCÉNTRICO PARA TENSOR</b> TORQUE ROD BUSHING</p> <p><b>200-1478</b></p> <p>OEM 47699-001, 438506C91</p> 	<p><b>NÚCLEO EXCÉNTRICO PARA TENSOR POLIURETANO</b> URETHANE TORQUE ROD BUSHING</p> <p><b>200-1478P</b></p> <p>OEM 47699-001, 438506C91</p> 	<p><b>NÚCLEO EXCÉNTRICO PARA TENSOR</b> TORQUE ROD BUSHING</p> <p><b>200-46734</b></p> <p>OEM 46734, 1693070C1</p> 
<p>SUSPENSIÓN: HENDRICKSON, FAMSA INTERNATIONAL/NAVISTAR</p> <p>ESPECIFICACIONES D= 3" DB= 13/16" LB= 5 11/16"</p>	<p>SUSPENSIÓN: HENDRICKSON, FAMSA INTERNATIONAL/NAVISTAR</p> <p>ESPECIFICACIONES D= 3" DB= 13/16" LB= 5 11/16" HD= 80</p>	<p>SUSPENSIÓN: HENDRICKSON SERIES 340-520, INTERNATIONAL/NAVISTAR</p> <p>ESPECIFICACIONES D= 2 3/4" DB= 13/16" LB= 5 11/16"</p>
<p><b>BUJE PARA TENSOR</b> TORQUE ROD BUSHING</p> <p><b>200-2607</b></p> <p>OEM 45477, INT. 322069C1</p> 	<p><b>BUJE PARA TENSOR POLIURETANO</b> URETHANE TORQUE ROD BUSHING</p> <p><b>200-2607P</b></p> <p>OEM 45477, INT. 322069C1</p> 	<p><b>BUJE PARA TENSOR</b> TORQUE ROD BUSHING</p> <p><b>200-2608</b></p> <p>OEM 46736</p> 
<p>SUSPENSIÓN: HENDRICKSON, FAMSA, INTERNATIONAL/NAVISTAR</p> <p>ESPECIFICACIONES DE= 3" DI= 1 1/8" L= 3 1/4"</p>	<p>SUSPENSIÓN: HENDRICKSON, FAMSA, INTERNATIONAL/NAVISTAR</p> <p>ESPECIFICACIONES DE= 3" DI= 1 1/8" L= 3 1/4" HD= 80</p>	<p>SUSPENSIÓN: HENDRICKSON, INTERNATIONAL/NAVISTAR</p> <p>ESPECIFICACIONES DE= 2 3/4" DI= 1 1/8" L= 3 1/4"</p>
<p><b>BUJE PARA TENSOR POLIURETANO</b> URETHANE TORQUE ROD BUSHING</p> <p><b>200-2608P</b></p> <p>OEM 46736</p> 	<p><b>NÚCLEO PARA TENSOR</b> SPRING RUBBER BUSHING</p> <p><b>200-0250</b></p> <p>OEM 681-325-02-50, RB-205</p> 	<p><b>NÚCLEO PARA TENSOR ALTO CONFINAMIENTO</b> SPRING RUBBER BUSHING</p> <p><b>200-0250HC</b></p> <p>OEM 681-325-02-50, RB-234</p> 
<p>SUSPENSIÓN: HENDRICKSON, INTERNATIONAL/NAVISTAR</p> <p>ESPECIFICACIONES DE= 2 3/4" DI= 1 1/8" L= 3 1/4" HD= 80</p>	<p>SUSPENSIÓN: FREIGHTLINER</p> <p>ESPECIFICACIONES D= 2 1/2" DB= 51/64" LB= 5 11/16" L= 7 1/2"</p>	<p>SUSPENSIÓN: FREIGHTLINER</p> <p>ESPECIFICACIONES D= 2 1/2" DB= 51/64" LB= 5 11/16" L= 7 1/2"</p>

<b>NÚCLEO PARA TENSOR POLIURETANO</b> URETHANE SPRING BUSHING		<b>NÚCLEO PARA TENSOR TORQUE ROD BUSHING</b>		<b>NÚCLEO PARA TENSOR POLIURETANO</b> URETHANE TORQUE ROD BUSHING	
<b>200-0250P</b>		<b>200-6587</b>		<b>200-6587P</b>	
OEM 681-325-02-50, RB-205		OEM 1134955 BOGE 6587		OEM 1134955, BOGE 6587	
					
SUSPENSIÓN:	FREIGHTLINER	SUSPENSIÓN:	VOLVO	SUSPENSIÓN:	VOLVO
ESPECIFICACIONES		ESPECIFICACIONES		ESPECIFICACIONES	
D= 2 1/2" DB= 51/64" LB= 5 11/16" L= 7 1/2" HD= 80		DE= 2 1/4" DB= 19/32" LB= 3 13/16"		DE= 2 1/4" DB= 19/32" LB= 3 13/16" HD=80	

<b>NÚCLEO PARA TENSOR TORQUE ROD BUSHING</b>		<b>NÚCLEO PARA TENSOR POLIURETANO</b> URETHANE TORQUE ROD BUSHING		<b>NÚCLEO PARA TENSOR TORQUE ROD BUSHING</b>	
<b>200-6716</b>		<b>200-6716P</b>		<b>200-46735</b>	
OEM 6813266716		OEM 6813266716		OEM 46735	
					
SUSPENSIÓN:	FREIGHTLINER FAS II	SUSPENSIÓN:	FREIGHTLINER FAS II	SUSPENSIÓN:	HENDRICKSON SERIES 380-520, MACK CAMELBACK
ESPECIFICACIONES		ESPECIFICACIONES		ESPECIFICACIONES	
D= 2 1/16" DB= 21/32" LB= 4 3/8"		D= 2 1/16" DB= 21/32" LB= 4 3/8" HD= 80		D= 2 3/4" L= 7" CUERDA= 1 1/4" 12 NF TORNILLO DE GRADO 5	

<b>NÚCLEO PARA TENSOR POLIURETANO</b> URETHANE TORQUE ROD BUSHING		<b>NÚCLEO PARA TENSOR TORQUE ROD BUSHING</b>		<b>NÚCLEO PARA TENSOR POLIURETANO</b> URETHANE TORQUE ROD BUSHING	
<b>200-46735P</b>		<b>200-44697</b>		<b>200-44697P</b>	
OEM 46735		OEM 44697		OEM 44697	
					
SUSPENSIÓN:	HENDRICKSON SERIES 380-520, MACK CAMELBACK	SUSPENSIÓN:	HENDRICKSON SERIES 380-520, KENWORTH AIR GLIDE 100, INTERNATIONAL/NAVISTAR	SUSPENSIÓN:	HENDRICKSON SERIES 380-520, KENWORTH AIR GLIDE 100, INTERNATIONAL/NAVISTAR
ESPECIFICACIONES		ESPECIFICACIONES		ESPECIFICACIONES	
D= 2 3/4" L= 7" CUERDA= 1 1/4" 12 NF TORNILLO DE GRADO 5 HD= 80		D= 2 3/4" L= 8 1/32" CUERDA= 1 1/4" 12 NF TORNILLO DE GRADO 5		D= 2 3/4" L= 8 1/32" CUERDA= 1 1/4" 12 NF TORNILLO DE GRADO 5 HD= 80	

<b>NÚCLEO PARA TENSOR ALTO CONFINAMIENTO</b> HIGH CONFINEMENT TORQUE ROD BUSHING		<b>NÚCLEO PARA TENSOR ALTO CONFINAMIENTO, POLIURETANO</b> HIGH CONFINEMENT URETHANE TORQUE ROD BUSHING		<b>NÚCLEO PARA TENSOR TORQUE ROD BUSHING</b>	
<b>200-44697HC</b>		<b>200-44697HCP</b>		<b>200-59217</b>	
OEM 44697		OEM 44697		OEM 59217	
					
SUSPENSIÓN:	HENDRICKSON SERIES 380-520, KENWORTH AIR GLIDE 100, INTERNATIONAL/NAVISTAR	SUSPENSIÓN:	HENDRICKSON SERIES 380-520, KENWORTH AIR GLIDE 100, INTERNATIONAL/NAVISTAR	SUSPENSIÓN:	HENDRICKSON SERIES 380-520, KENWORTH AIR GLIDE 100, INTERNATIONAL/NAVISTAR
ESPECIFICACIONES		ESPECIFICACIONES		ESPECIFICACIONES	
D= 2 3/4" L= 8 1/32" CUERDA= 1 1/4" 12 NF TORNILLO DE GRADO 5		D= 2 3/4" L= 8 1/32" CUERDA= 1 1/4" 12 NF TORNILLO DE GRADO 5 HD= 80		D= 2" L= 8 1/32" CUERDA= 1 1/4" 12 NF TORNILLO DE GRADO 5	

<p><b>NÚCLEO PARA TENSOR POLIURETANO</b> URETHANE TORQUE ROD BUSHING</p> <p><b>200-59217P</b></p> <p>OEM 59217</p> 	<p><b>NÚCLEO PARA TENSOR PARA TENSOR</b> TORQUE ROD BUSHING</p> <p><b>200-638938</b></p> <p>OEM 638938</p> 	<p><b>NÚCLEO PARA TENSOR POLIURETANO</b> URETHANE TORQUE ROD BUSHING</p> <p><b>200-638938P</b></p> <p>OEM 638938</p> 
<p>SUSPENSIÓN: HENDRICKSON SERIES 380-520, KENWORTH AIR GLIDE 100, INTERNATIONAL/NAVISTAR</p> <p><b>ESPECIFICACIONES</b> D=2" L=8 1/32" CUERDA=1 1/4" 12 NF TORNILLO DE GRADO 5 HD=80</p>	<p>SUSPENSIÓN: VOLVO-MASA REACCIÓN ANGULAR</p> <p><b>ESPECIFICACIONES</b> DE= 3 47/64" DB= 29/32" LB= 5 63/64"</p>	<p>SUSPENSIÓN: VOLVO-MASA REACCIÓN ANGULAR</p> <p><b>ESPECIFICACIONES</b> DE= 3 47/64" DB= 29/32" LB= 5 63/64" HD= 80</p>
<p><b>DADO PARA INSTALACIÓN NTS</b> 200-447691 Y 200-447691P INSTALLATION TOOL FOR 200-447691 AND 200-447691P</p> <p><b>PBA-101</b></p> <p>OEM</p> 	<p><b>BUJE PARA MUELLE</b> SPRING RUBBER BUSHING</p> <p><b>200-6512</b></p> <p>OEM HRI-HBUS41,RB-175</p> 	<p><b>BUJE PARA MUELLE POLIURETANO</b> URETHANE SPRING BUSHING</p> <p><b>200-6512P</b></p> <p>OEM HRI-HBUS41,RB-175</p> 
<p>SUSPENSIÓN:</p> <p><b>ESPECIFICACIONES</b> 200-447691 200-447691P</p>	<p>SUSPENSIÓN: FREIGHTLINER</p> <p><b>ESPECIFICACIONES</b> D= 1 3/4" DB= 21/32" L= 6 3/4" LB= 5 3/8"</p>	<p>SUSPENSIÓN: FREIGHTLINER</p> <p><b>ESPECIFICACIONES</b> D= 1 3/4" DB= 21/32" L= 6 3/4" LB= 5 3/8" HD= 80</p>
<p><b>BUJE PARA MUELLE</b> SPRING RUBBER BUSHING</p> <p><b>200-6514</b></p> <p>OEM B65-1007</p> 	<p><b>BUJE PARA MUELLE POLIURETANO</b> SPRING URETHANE BUSHING</p> <p><b>200-6514P</b></p> <p>OEM B65-1007</p> 	<p><b>BUJE PARA MUELLE</b> SPRING RUBBER BUSHING</p> <p><b>200-100K254M</b></p> <p>OEM 100K254M, RB-189</p> 
<p>SUSPENSIÓN: KENWORTH</p> <p><b>ESPECIFICACIONES</b> DE= 2 5/64" L= 7 1/2"</p>	<p>SUSPENSIÓN: KENWORTH</p> <p><b>ESPECIFICACIONES</b> DE= 2 5/64" L= 7 1/2" HD= 80</p>	<p>SUSPENSIÓN: MACK CH600</p> <p><b>ESPECIFICACIONES</b> DE= 1 7/8" L= 6 3/4"</p>
<p><b>BUJE PARA MUELLE</b> SPRING RUBBER BUSHING</p> <p><b>200-249</b></p> <p>OEM B65-1001, RB-249</p> 	<p><b>BUJE PARA MUELLE POLIURETANO</b> SPRING URETHANE BUSHING</p> <p><b>200-249P</b></p> <p>OEM B65-1001, RB-249</p> 	<p><b>BUJE PARA MUELLE</b> SPRING RUBBER BUSHING</p> <p><b>200-295</b></p> <p>OEM RB-295</p> 
<p>SUSPENSIÓN: KENWORTH T-2000</p> <p><b>ESPECIFICACIONES</b> DE= 1 3/4" L= 7"</p>	<p>SUSPENSIÓN: KENWORTH T-2000</p> <p><b>ESPECIFICACIONES</b> DE= 1 3/4" L= 7" HD= 80</p>	<p>SUSPENSIÓN: KENWORTH T-2000</p> <p><b>ESPECIFICACIONES</b> DE= 1 3/4" L= 7 1/2"</p>

<b>BUJE PARA MUELLE POLIURETANO</b> SPRING URETHANE BUSHING <b>200-295P</b> OEM RB-295 	<b>BUJE PARA MUELLE</b> SPRING RUBBER BUSHING <b>200-503611C1</b> OEM 503611C1,RB-161 	<b>BUJE PARA MUELLE</b> SPRING RUBBER BUSHING <b>200-6516</b> OEM B65-6005 
SUSPENSION: KENWORTH T-2000	SUSPENSION: INTERNATIONAL/NAVISTAR	SUSPENSION: KENWORTH
ESPECIFICACIONES DE= 1 3/4" L= 7 1/2" HD= 80	ESPECIFICACIONES DE= 1 3/4" L= 7"	ESPECIFICACIONES DE=1 3/4" L=6 3/4"

<b>BUJE PARA MUELLE POLIURETANO</b> SPRING URETHANE BUSHING <b>200-6516P</b> OEM B65-6005 	<b>BUJE LATERAL PARA VIGA BALANCEADORA</b> BEAM END BUSHING <b>200-459</b> OEM 45900 	<b>BUJE LATERAL PARA VIGA BALANCEADORA KIT</b> BEAM END BUSHING KIT <b>200-459K</b> OEM 34013-73 
SUSPENSION: KENWORTH	SUSPENSION: HENDRICKSON SERIE 380/460	SUSPENSION: HENDRICKSON SERIE 380/460
ESPECIFICACIONES DE=1 3/4" L=6 3/4" HD=80	ESPECIFICACIONES DE= 4 3/8" DI= 2 1/2" L= 5 3/4"	ESPECIFICACIONES 1-BUJE LATERAL 200-459 1-ADAPTADOR 200-400

<b>BUJE LATERAL PARA VIGA BALANCEADORA POLIURETANO</b> URETHANE BEAM END BUSHING <b>200-459P</b> OEM 45900 	<b>BUJE LATERAL PARA VIGA BALANCEADORA POLIURETANO KIT</b> URETHANE BEAM END BUSHING KIT <b>200-459KP</b> OEM 34013-73 	<b>BUJE LATERAL PARA VIGA BALANCEADORA</b> BEAM END BUSHING <b>200-298</b> OEM 29878 
SUSPENSION: HENDRICKSON SERIE 380/460	SUSPENSION: HENDRICKSON SERIE 380/460	SUSPENSION: HENDRICKSON SERIE 480/520
ESPECIFICACIONES DE= 4 3/8" DI= 2 1/2" L= 5 3/4" HD= 80	ESPECIFICACIONES 1-BUJE LATERAL 200-459P 1-ADAPTADOR 200-400	ESPECIFICACIONES DE= 4 3/8" DI= 2 1/2" L= 5 3/4"

<b>BUJE LATERAL PARA VIGA BALANCEADORA KIT</b> BEAM END BUSHING KIT <b>200-298K</b> OEM 34013-50 	<b>BUJE LATERAL PARA VIGA BALANCEADORA POLIURETANO</b> URETHANE BEAM END BUSHING <b>200-298P</b> OEM 29878 	<b>BUJE LATERAL PARA VIGA BALANCEADORA POLIURETANO KIT</b> URETHANE BEAM END BUSHING KIT <b>200-298KP</b> OEM 34013-50 
SUSPENSION: HENDRICKSON SERIE 480/520	SUSPENSION: HENDRICKSON SERIE 480/520	SUSPENSION: HENDRICKSON SERIE 480/520
ESPECIFICACIONES 1-BUJE LATERAL 200-298 1-ADAPTADOR 200-400	ESPECIFICACIONES DE= 4 3/8" DI= 2 1/2" L= 5 3/4" HD= 80	ESPECIFICACIONES 1-BUJE LATERAL 200-298P 1-ADAPTADOR 200-400

<b>ADAPTADOR PARA BUJE LATERAL</b> BEAM END ADAPTER KIT		<b>BUJE CENTRAL PARA VIGA BALANCEADORA</b> BEAM CENTER BUSHING		<b>BUJE CENTRAL PARA VIGA BALANCEADORA</b> BEAM CENTER BUSHING	
<b>200-400</b> OEM 45000-7		<b>200-059</b> OEM 05919		<b>200-494</b> OEM 49400	
					
SUSPENSIÓN:	HENDRICKSON SERIE 480/520	SUSPENSIÓN:	HENDRICKSON SERIE 400	SUSPENSIÓN:	HENDRICKSON SERIE 400
<b>ESPECIFICACIONES</b> L= 7 3/4"		<b>ESPECIFICACIONES</b> DE 1= 4 3/4" DE 2= 3 1/2" L 1= 7" L 2= 12"		<b>ESPECIFICACIONES</b> DE 1= 4 3/4" DE 2= 3 1/2" L 1= 7" L 2= 12"	

<b>BUJE CENTRAL PARA VIGA BALANCEADORA POLIURETANO</b> URETHANE BEAM CENTER BUSHING		<b>KIT PARA VIGA BALANCEADORA 44,000 LBS</b> BEAM BUSHING KIT 44,000 LBS		<b>KIT PARA VIGA BALANCEADORA 44,000 LBS POLIURETANO</b> URETHANE BEAM BUSHING KIT 44,000 LBS	
<b>200-494P</b> OEM 49400		<b>200-420</b> OEM		<b>200-420P</b> OEM	
					
SUSPENSIÓN:	HENDRICKSON SERIE 400	SUSPENSIÓN:	HENDRICKSON SERIE 380/460	SUSPENSIÓN:	HENDRICKSON SERIE 380/460
<b>ESPECIFICACIONES</b> DE 1= 4 3/4" DE 2= 3 1/2" L 1= 7" L 2= 12" HD= 80		<b>ESPECIFICACIONES</b> 2-BUJE CENTRAL 200-494 4-BUJE LATERAL 200-459		<b>ESPECIFICACIONES</b> 2-BUJE CENTRAL 200-494P 4-BUJE LATERAL 200-459P HD= 80	

<b>KIT PARA VIGA BALANCEADORA 44,000 LBS</b> BEAM BUSHING KIT 44,000 LBS		<b>KIT PARA VIGA BALANCEADORA 44,000 LBS POLIURETANO</b> URETHANE BEAM BUSHING KIT 44,000 LBS		<b>BUJE LATERAL</b> BAR PIN BUSHING	
<b>200-420K</b> OEM		<b>200-420KP</b> OEM		<b>200-34013</b> OEM 34013-087	
					
SUSPENSIÓN:	HENDRICKSON SERIE 380/460	SUSPENSIÓN:	HENDRICKSON SERIE 380/460	SUSPENSIÓN:	HENDRICKSON RT/RTE/RU/RS/HN
<b>ESPECIFICACIONES</b> 2-BUJE CENTRAL 200-494 4-BUJE LATERAL 200-459 4-ADAPTADORES 200-400		<b>ESPECIFICACIONES</b> 2-BUJE CENTRAL 200-494P 4-BUJE LATERAL 200-459P 4-ADAPTADORES 200-400 HD= 80		<b>ESPECIFICACIONES</b> BUJE DE= 4 3/8" DB= 1 1/16" LB= 8 17/32" // 4-ARANDELAS 2-TORNILLOS DE 1" X 5 7/8" GRADO 5 2-TUERCAS GRIPICO HEXAGONAL	

<b>BUJE LATERAL POLIURETANO</b> URETHANE BAR PIN BUSHING		<b>BUJE LATERAL KIT</b> BAR PIN BUSHING KIT		<b>BUJE LATERAL KIT POLIURETANO</b> URETHANE BAR PIN BUSHING KIT	
<b>200-34013P</b> OEM 34013-087		<b>200-34013K</b> OEM 34013-088		<b>200-34013KP</b> OEM 34013-088	
					
SUSPENSIÓN:	HENDRICKSON RT/RTE/RU/RS/HN	SUSPENSIÓN:	HENDRICKSON RT/RTE/RU/RS/HN	SUSPENSIÓN:	HENDRICKSON RT/RTE/RU/RS/HN
<b>ESPECIFICACIONES</b> BUJE DE= 4 3/8" DB= 1 1/16" LB= 8 17/32" HD= 80 // 4-ARANDELAS 2-TORNILLOS DE 1" X 5 7/8" GRADO 5 2-TUERCAS GRIPICO HEXAGONAL		<b>ESPECIFICACIONES</b> 1-200-34013 2-LAINAS DE ALINEACION 2-TORNILLOS DE 1" X 5 7/8" GRADO 5 2-TUERCAS GRIPICO HEXAGONAL 4-ARANDELAS		<b>ESPECIFICACIONES</b> 1-200-34013P 2-LAINAS DE ALINEACION 2-TORNILLOS DE 1" X 5 7/8" GRADO 5 2-TUERCAS GRIPICO HEXAGONAL 4-ARANDELAS HD= 80	

<b>SOPORTE PARA SUSPENSIÓN POLIURETANO</b> URETHANE BOLSTER SPRING		<b>NÚCLEO ROSCADO KIT</b> THREADED PIN		<b>BUJE CENTRAL PARA BALANCÍN</b> EQUALIZER BUSHING	
<b>200-449377P</b> OEM 49377-000		<b>200-179531</b> OEM K179-531		<b>200-47420</b> OEM 47420	
					
SUSPENSIÓN:	HENDRICKSON HN-402 462-460	SUSPENSIÓN:	KENWORTH AIRGLIDE 200	SUSPENSIÓN:	HENDRICKSON E-4
<b>ESPECIFICACIONES</b> ALTURA= 5 7/16" ANCHO= 7 3/4" BARRENO= 1/2" HD= 80		<b>ESPECIFICACIONES</b> DB= 13/16" LB= 8 21/32" L= 10 1/4"		<b>ESPECIFICACIONES</b> DE= 2 3/4" DI= 1" L= 4 5/8"	

<b>BUJE CENTRAL PARA BALANCÍN POLIURETANO</b> URETHANE EQUALIZER BUSHING		<b>BUJE LATERAL PARA BALANCÍN</b> EQUALIZER BUSHING		<b>BUJE LATERAL PARA BALANCÍN POLIURETANO</b> URETHANE EQUALIZER BUSHING	
<b>200-47420P</b> OEM 47420		<b>200-47421</b> OEM 47421,RB-167		<b>200-47421P</b> OEM 47421,RB-167	
					
SUSPENSIÓN:	HENDRICKSON E-4	SUSPENSIÓN:	HENDRICKSON E4	SUSPENSIÓN:	HENDRICKSON E4
<b>ESPECIFICACIONES</b> DE= 2 3/4" DI= 1" L= 4 5/8" HD= 80		<b>ESPECIFICACIONES</b> DE= 2 3/8" DI= 7/8" L= 3 1/8"		<b>ESPECIFICACIONES</b> DE= 2 3/8" DI= 7/8" L= 3 1/8" HD= 80	

<b>BUJE PARA TENSOR</b> TORQUE ROD BUSHING		<b>BUJE DE RECUPERACIÓN</b> RECOVERY BUSHING		<b>BUJE DE RECUPERACIÓN POLIURETANO</b> URETHANE RECOVERY BUSHING	
<b>200-47692</b> OEM 47692, 13945-01		<b>200-57988K</b> OEM 57988-000		<b>200-57988KP</b> OEM 57988-000	
					
SUSPENSIÓN:	HENDRICKSON E4 FREIGHTLINER FH36-40, REYCO 181	SUSPENSIÓN:	HENDRICKSON HAS 120,130, 190, 210, 230	SUSPENSIÓN:	HENDRICKSON HAS 120,130, 190, 210, 230
<b>ESPECIFICACIONES</b> DE= 2 1/32" DI= 7/8" L= 3"		<b>ESPECIFICACIONES</b> DE= 1 15/16" DI= 5/8" L= 3"		<b>ESPECIFICACIONES</b> DE= 1 15/16" DI= 5/8" L= 3" HD= 80	

<b>BUJE DE RECUPERACIÓN</b> RECOVERY BUSHING		<b>BUJE DE RECUPERACIÓN POLIURETANO</b> URETHANE RECOVERY BUSHING		<b>BUJE PARA MUELLE POLIURETANO</b> SPRING URETHANE BUSHING	
<b>200-57989K</b> OEM 57989-000		<b>200-57989KP</b> OEM 57989-000		<b>200-47700P</b> OEM 3526665C1	
					
SUSPENSIÓN:	HENDRICKSON HAS 120,130, 190, 210, 230	SUSPENSIÓN:	HENDRICKSON HAS 120,130, 190, 210, 230	SUSPENSIÓN:	INTERNATIONAL/NAVISTAR
<b>ESPECIFICACIONES</b> DE= 2 1/2" DI= 9/16" L= 3 5/8"		<b>ESPECIFICACIONES</b> DE= 2 1/2" DI= 9/16" L= 3 5/8" HD= 80		<b>ESPECIFICACIONES</b> DE= 1 27/32" DI= 3/4" L= 4 3/16" HD= 80	



<b>BUJE CENTRAL PARA BALANCIN</b> EQUALIZER BUSHING <b>200-497501C2</b> OEM 497501C2 	<b>BUJE CENTRAL PARA BALANCIN POLIURETANO</b> URETHANE EQUALIZER BUSHING <b>200-497501C2P</b> OEM 497501C2 	<b>BUJE PARA MUELLE</b> SPRING RUBBER BUSHING <b>200-68032</b> OEM 6803220105, RB-211 
SUSPENSION: INTERNATIONAL/NAVISTAR	SUSPENSION: INTERNATIONAL/NAVISTAR	SUSPENSION: FREIGHTLINER BUSINESS CLASS
<b>ESPECIFICACIONES</b> DE= 2 1/2" DI= 1 1/32" L= 4 23/32"	<b>ESPECIFICACIONES</b> DE= 2 1/2" DI= 1 1/32" L= 4 23/32" HD= 80	<b>ESPECIFICACIONES</b> DE= 2 1/4" DI= 13/16" L= 4 1/4"

<b>BUJE PARA MUELLE POLIURETANO</b> SPRING URETHANE BUSHING <b>200-68032P</b> OEM 6803220105, RB-211 	<b>BUJE PARA MUELLE</b> SPRING RUBBER BUSHING <b>200-68033</b> OEM 	<b>BUJE PARA MUELLE POLIURETANO</b> SPRING URETHANE BUSHING <b>200-68033P</b> OEM 
SUSPENSION: FREIGHTLINER BUSINESS CLASS	SUSPENSION: FREIGHTLINER BUSINESS CLASS	SUSPENSION: FREIGHTLINER BUSINESS CLASS
<b>ESPECIFICACIONES</b> DE= 2 1/4" DI= 13/16" L= 4 1/4" HD= 80	<b>ESPECIFICACIONES</b> DE= 2 1/4" DI= 3/4" L= 4 1/4"	<b>ESPECIFICACIONES</b> DE= 2 1/4" DI= 3/4" L= 4 1/4" HD= 80

<b>BUJE PARA MUELLE</b> SPRING RUBBER BUSHING <b>200-10QK253M</b> OEM 10QK253M RB-188 	<b>BUJE PARA MUELLE</b> SPRING RUBBER BUSHING <b>200-10QK260</b> OEM 10QK260 RB-187 CON TRATAMIENTO TÉRMICO / HEAT TREATED 	<b>SOPORTE DE DESGASTE</b> WEAR PAD <b>200-565574</b> OEM 565574000 
SUSPENSION: MACK CH600	SUSPENSION: MACK SERIE ST	SUSPENSION: HENDRICKSON HAS/120/150/230/360/400/460
<b>ESPECIFICACIONES</b> DE= 1.890" (48mm) DI= 0.945" (24mm) L= 3.504" (89mm)	<b>ESPECIFICACIONES</b> DE= 2 1/2" DI= 1" L= 4 1/4"	<b>ESPECIFICACIONES</b> ALTO= 1 9/16" ANCHO= 3 11/16" LARGO= 3 3/16" HD= 70

<b>SOPORTE DE DESGASTE</b> WEAR PAD <b>200-565575</b> OEM 56557-002 	<b>SOPORTE DE MUELLE POLIURETANO</b> URETHANE WEAR PAD <b>200-571960C1P</b> OEM 571960C1 	<b>BUJE TRIFUNCIONAL CORTO</b> BEAM END BUSHING <b>200-25364</b> OEM D-25364 
SUSPENSION: HENDRICKSON HAS/120/150/230/360/400/460	SUSPENSION: INTERNATIONAL / NAVISTAR	SUSPENSION: HENDRICKSON
<b>ESPECIFICACIONES</b> ALTO= 2 7/8" ANCHO= 3" LARGO= 6 3/4" HD= 70	<b>ESPECIFICACIONES</b> ALTURA= 2" ANCHO= 3 1/2" LARGO= 5 1/2" HD= 80	<b>ESPECIFICACIONES</b> DE= 6 5/16" DI= 1 1/4" L= 3 5/8"

<p><b>BUJE TRIFUNCIONAL CORTO POLIURETANO</b> URETHANE BEAM END BUSHING</p> <p><b>200-25364P</b> OEM D-25364</p>  <p>SUSPENSIÓN: HENDRICKSON</p> <p><b>ESPECIFICACIONES</b> DE= 6" DI= 1 1/4" L= 3 5/8" HD= 80</p>	<p><b>BUJE TRIFUNCIONAL CORTO / KIT</b> BEAM END RUBBER BUSHING KIT</p> <p><b>200-26321</b> OEM S-26321</p>  <p>SUSPENSIÓN: HENDRICKSON</p> <p><b>ESPECIFICACIONES</b> 1-BUJE TRIFUNCIONAL CORTO 200-25364 2-RONDANAS NYLON 1-TORNILLO Y TUERCA 2- ARANDELAS 1-ACEITE</p>	<p><b>BUJE TRIFUNCIONAL CORTO POLIURETANO / KIT</b> URETHANE BEAM END BUSHING KIT</p> <p><b>200-26321P</b> OEM S-26321</p>  <p>SUSPENSIÓN: HENDRICKSON</p> <p><b>ESPECIFICACIONES</b> 1-BUJE TRIFUNCIONAL CORTO 200-25364P 2-RONDANAS NYLON 1-TORNILLO Y TUERCA 2- ARANDELAS 1-ACEITE</p>
<p><b>BUJE TRIFUNCIONAL MERITOR</b> TRIFUNCTIONAL BUSHING MERITOR</p> <p><b>200-21227380</b> OEM M21227380</p>  <p>SUSPENSIÓN: MERITOR</p> <p><b>ESPECIFICACIONES</b> DE= 5 15/16" DI 1= 1 37/64" DI 2= 57/64 L= 5 23/32"</p>	<p><b>BUJE TRIFUNCIONAL MERITOR POLIURETANO</b> URETHANE TRIFUNCTIONAL BUSHING MERITOR</p> <p><b>200-21227380P</b> OEM M21227380</p>  <p>SUSPENSIÓN: MERITOR</p> <p><b>ESPECIFICACIONES</b> DE= 5 15/16" DI 1= 1 37/64" DI 2= 57/64 L= 5 23/32" HD= 80</p>	<p><b>BUJE TRIFUNCIONAL MERITOR / KIT</b> TRIFUNCTIONAL BUSHING MERITOR KIT</p> <p><b>200-11205</b> OEM S11205</p>  <p>SUSPENSIÓN: MERITOR</p> <p><b>ESPECIFICACIONES</b> 1-BUJE TRIFUNCIONAL MERITOR 200-21227380 2-RONDANAS NYLON 1-TORNILLO Y TUERCA 7/8 x 9 7/8 2-ARANDELAS 1-ACEITE 1-INCERTO METALICO</p>
<p><b>BUJE TRIFUNCIONAL MERITOR POLIURETANO / KIT</b> URETHANE TRIFUNCTIONAL BUSHING MERITOR KIT</p> <p><b>200-11205P</b> OEM S11205</p>  <p>SUSPENSIÓN: MERITOR</p> <p><b>ESPECIFICACIONES</b> 1-BUJE TRIFUNCIONAL MERITOR 200-21227380P 2-RONDANAS NYLON 1-TORNILLO Y TUERCA 7/8 x 9 7/8 2-ARANDELAS 1-ACEITE 1-INCERTO METALICO</p>	<p><b>BUJE LATERAL</b> BEAM END RUBBER BUSHING</p> <p><b>200-3558</b> OEM C-3558</p>  <p>SUSPENSIÓN: HENDRICKSON DE AIRE SERIE HT</p> <p><b>ESPECIFICACIONES</b> DE= 6" DI= 1 1/4" L= 6 3/4"</p>	<p><b>BUJE LATERAL POLIURETANO</b> URETHANE BEAM END BUSHING</p> <p><b>200-3558P</b> OEM C-3558</p>  <p>SUSPENSIÓN: HENDRICKSON DE AIRE SERIE HT</p> <p><b>ESPECIFICACIONES</b> DE= 6" DI= 1 1/4" L= 6 3/4" HD= 80</p>
<p><b>BUJE LATERAL KIT</b> BEAM END RUBBER BUSHING KIT</p> <p><b>200-6914</b> OEM A-6914</p>  <p>SUSPENSIÓN: HENDRICKSON DE AIRE SERIE HT</p> <p><b>ESPECIFICACIONES</b> 1-BUJE LATERAL 200-3558 1-TORNILLO 1 1/8" x 9 1/2" GRADO 5 1-TUERCA GRIPCO HEXAGONAL 1-ACEITE LUBRICANTE P/ ENSAMBLE 2-RONDANAS PLASTICO 1-TUBO LONGITUDINAL PLASTICO</p>	<p><b>BUJE LATERAL KIT POLIURETANO</b> URETHANE BEAM END BUSHING KIT</p> <p><b>200-6914P</b> OEM A-6914</p>  <p>SUSPENSIÓN: HENDRICKSON DE AIRE SERIE HT</p> <p><b>ESPECIFICACIONES</b> 1-BUJE LATERAL 200-3558P 1-TORNILLO 1 1/8" x 9 1/2" GRADO 5 1-TUERCA GRIPCO HEXAGONAL 1-ACEITE LUBRICANTE P/ ENSAMBLE 2-RONDANAS PLASTICO 1-TUBO LONGITUDINAL PLASTICO HD=80</p>	<p><b>BUJE LATERAL KIT ALINEACIÓN RÁPIDA</b> QUICK ALIGNMENT BEAM END RUBBER BUSHING KIT</p> <p><b>200-6914QA</b> OEM S-21166</p>  <p>SUSPENSIÓN: HENDRICKSON DE AIRE SERIE HT</p> <p><b>ESPECIFICACIONES</b> 1-BUJE LATERAL 200-3558 1-TORNILLO QUICK ALIGNMENT 1-ACEITE LUBRICANTE P/ ENSAMBLE 2- RONDANAS DE ALINEACION</p>

<p><b>BUJE LATERAL KIT ALINEACIÓN RÁPIDA POLIURETANO</b> URETHANE QUICK ALIGNMENT BEAM END BUSHING KIT</p> <p><b>200-6914QAP</b></p> <p>OEM S-21166</p> 	<p><b>TORNILLO Y TUERCA</b> NUT AND BOLT</p> <p><b>PBA-001</b></p> <p>OEM</p> 	<p><b>TORNILLO, TUERCA Y TUBO</b> NUT, BOLT AND TUBE SLEEVE</p> <p><b>PBA-002</b></p> <p>OEM S-3646</p> 
<p>SUSPENSIÓN: HENDRICKSON DE AIRE SERIE HT</p> <p><b>ESPECIFICACIONES</b> 1-BUJE LATERAL 200-3558P 1-TORNILLO QUICK ALIGNMENT 1-ACEITE LUBRICANTE P/ ENSAMBLE 2- RONDANAS DE ALINEACIÓN</p>	<p>SUSPENSIÓN: HENDRICKSON DE AIRE SERIE HT</p> <p><b>ESPECIFICACIONES</b> TORNILLO 1 1/8" x 9 1/2" GRADO 5 TUERCA GRIPCO HEXAGONAL</p>	<p>SUSPENSIÓN: HENDRICKSON DE AIRE SERIE HT</p> <p><b>ESPECIFICACIONES</b> TORNILLO 1 1/8" x 9 1/2" GRADO 5 TUERCA GRIPCO HEXAGONAL. TUBO LONGITUDINAL PLÁSTICO</p>
<p><b>TUBO LONGITUDINAL Y RONDANAS</b> TUBE SLEEVE AND WEAR WASHERS</p> <p><b>PBA-005</b></p> <p>OEM</p> 	<p><b>TUBO LONGITUDINAL</b> TUBE SLEEVE</p> <p><b>PBA-006</b></p> <p>OEM B-7342</p> 	<p><b>RONDANAS</b> WEAR WASHERS</p> <p><b>PBA-007</b></p> <p>OEM S-11613</p> 
<p>SUSPENSIÓN: HENDRICKSON DE AIRE SERIE HT</p> <p><b>ESPECIFICACIONES</b> 1-TUBO LONGITUDINAL DE PLÁSTICO 2-RONDANAS DE PLÁSTICO</p>	<p>SUSPENSIÓN: HENDRICKSON DE AIRE SERIE HT</p> <p><b>ESPECIFICACIONES</b> TUBO LONGITUDINAL DE PLÁSTICO</p>	<p>SUSPENSIÓN: HENDRICKSON DE AIRE SERIE HT</p> <p><b>ESPECIFICACIONES</b> 2-RONDANAS DE PLÁSTICO</p>
<p><b>TORNILLO ALINEACIÓN RÁPIDA</b> QUICK ALIGNMENT BOLT</p> <p><b>PBA-008</b></p> <p>OEM S-24679</p> 	<p><b>RONDANA CONCÉNTRICA</b> CONCENTRIC ALIGNMENT COLLAR</p> <p><b>PBA-009</b></p> <p>OEM C-20924</p> 	<p><b>RONDANA EXCÉNTRICA</b> ECCENTRIC ALIGNMENT COLLAR</p> <p><b>PBA-010</b></p> <p>O925</p> 
<p>SUSPENSIÓN: HENDRICKSON DE AIRE SERIE HT</p> <p><b>ESPECIFICACIONES</b> TORNILLO Q.A. (ALINEACIÓN RÁPIDA)</p>	<p>SUSPENSIÓN: HENDRICKSON DE AIRE SERIE HT</p> <p><b>ESPECIFICACIONES</b> RONDANA CONCÉNTRICA Q.A. (ALINEACIÓN RÁPIDA)</p>	<p>SUSPENSIÓN: HENDRICKSON DE AIRE SERIE HT</p> <p><b>ESPECIFICACIONES</b> RONDANA EXCÉNTRICA Q.A. (ALINEACIÓN RÁPIDA)</p>
<p><b>BUJE CENTRAL PARA SUSPENSIÓN</b> PIVOT ARM BUSHING</p> <p><b>200-01</b></p> <p>OEM 1027371, KO66-184</p> 	<p><b>BUJE CENTRAL PARA SUSPENSIÓN POLIURETANO</b> URETHANE PIVOT ARM BUSHING</p> <p><b>200-01P</b></p> <p>OEM 1027371, KO66-184</p> 	<p><b>BUJE CENTRAL PARA BALANCÍN</b> TRUNNION BUSHING</p> <p><b>200-02</b></p> <p>OEM KO66-232</p> 
<p>SUSPENSIÓN: PAGE LM-3000</p> <p><b>ESPECIFICACIONES</b> DE= 4 1/2" DI= 3 1/2" L= 4 1/4"</p>	<p>SUSPENSIÓN: PAGE LM-3000</p> <p><b>ESPECIFICACIONES</b> DE= 4 1/2" DI= 3 1/2" L= 4 1/4" HD=80</p>	<p>SUSPENSIÓN: KENWORTH BIG SIX</p> <p><b>ESPECIFICACIONES</b> DE= 5" DI= 4" L= 4 5/8"</p>

<b>BUJE CENTRAL PARA BALANCÍN POLIURETANO</b> URETHANE TRUNNION BUSHING <b>200-02P</b> OEM KO66-232	<b>BUJE CENTRAL PARA MUÑÓN</b> TRUNNION BUSHING <b>200-3579</b> OEM UXA-0160-000	<b>BUJE CENTRAL PARA MUÑÓN POLIURETANO</b> URETHANE TRUNNION BUSHING <b>200-3579P</b> OEM UXA-0160-000
SUSPENSIÓN: KENWORTH BIG SIX	SUSPENSIÓN: FRUEHAUF VILCHIS	SUSPENSIÓN: FRUEHAUF VILCHIS
ESPECIFICACIONES DE= 5" DI= 4" L= 4 5/8" HD= 80	ESPECIFICACIONES DE= 5" DI= 4" L= 8 5/16"	ESPECIFICACIONES DE= 5" DI= 4" L= 8 5/16" HD= 80

<b>BUJE PARA SUSPENSIÓN VILCHIS</b> RUBBER BUSHING <b>200-3580</b> OEM	<b>BUJE PARA SUSPENSIÓN VILCHIS POLIURETANO</b> URETHANE BUSHING <b>200-3580P</b> OEM	<b>BUJE CENTRAL PARA MUÑÓN</b> TRUNNION BUSHING <b>200-0149</b> OEM 10QK149
SUSPENSIÓN: VILCHIS	SUSPENSIÓN: VILCHIS	SUSPENSIÓN: MACK
ESPECIFICACIONES DE= 2 1/2" DI= 1 1/2" L= 4 1/8"	ESPECIFICACIONES DE= 2 1/2" DI= 1 1/2" L= 4 1/8" HD= 80	ESPECIFICACIONES DE= 4 7/16" DI= 3 7/16" L= 7 9/16"

<b>BUJE CENTRAL PARA MUÑÓN</b> TRUNNION BUSHING <b>200-0219P2</b> OEM 10QK219P2	<b>BUJE CENTRAL PARA MUÑÓN POLIURETANO</b> URETHANE TRUNNION BUSHING <b>200-0219P2P</b> OEM 10QK219P2	<b>BUJE PARA MUÑÓN POLIURETANO</b> URETHANE TRUNNION BUSHING <b>200-90008011P</b> OEM 90008011
SUSPENSIÓN: MACK CAMELBACK	SUSPENSIÓN: MACK CAMELBACK	SUSPENSIÓN: HUTCH, HYSTER
ESPECIFICACIONES DE= 4 11/16" DI= 3 7/16" L= 6 5/16"	ESPECIFICACIONES DE= 4 11/16" DI= 3 7/16" L= 6 5/16" HD= 80	ESPECIFICACIONES DE= 4 7/16" DI= 3 7/16" LARGO=5 3/4" HD= 80

<b>BUJE CENTRAL PARA MUÑÓN POLIURETANO</b> URETHANE TRUNNION BUSHING <b>200-91008022P</b> OEM 91008022	<b>BUJE PARA MUÑÓN POLIURETANO</b> URETHANE TRUNNION BUSHING <b>200-10QK130P1P</b> OEM 10Q1301P	<b>BUJE PARA BARRA DE TORSIÓN</b> STABILIZER BAR BUSHING <b>200-450</b> OEM KO66-450
SUSPENSIÓN: NEWAY TS/US/USR	SUSPENSIÓN: MACK	SUSPENSIÓN: KENWORTH AIRGLIDE 200
ESPECIFICACIONES DE= 5" DI= 4" L= 8 3/4" HD= 80	ESPECIFICACIONES DE= 4 3/8" DI= 3 3/8" L= 8 3/8" HD= 80	ESPECIFICACIONES DE= 3.060" DI= 2.110" L= 2.930"

<p><b>BUJE PARA BARRA DE TORSIÓN POLIURETANO</b> URETHANE STABILIZER BAR BUSHING</p> <p><b>200-450P</b> OEM KO66-450</p> 	<p><b>BUJE PARA BARRA DE TORSIÓN</b> STABILIZER BAR BUSHING</p> <p><b>200-460</b> OEM KO66-460</p> 	<p><b>BUJE PARA BARRA DE TORSIÓN</b> STABILIZER BAR BUSHING</p> <p><b>200-477</b> OEM KO66-477</p> 
<p>SUSPENSIÓN: KENWORTH AIRGLIDE 200</p> <p>ESPECIFICACIONES DE= 3.060" DI=2.110" L= 2.930" HD=80</p>	<p>SUSPENSIÓN: KENWORTH AIRGLIDE 200</p> <p>ESPECIFICACIONES DE= 3.060" DI= 2.260" L= 2.930"</p>	<p>SUSPENSIÓN: KENWORTH AIRGLIDE 200</p> <p>ESPECIFICACIONES DE= 3.120" DI= 2.260" L= 2.930"</p>
<p><b>BUJE PARA BARRA DE TORSIÓN</b> STABILIZER BAR BUSHING</p> <p><b>200-478</b> OEM KO66-478</p> 	<p><b>BUJE PARA BARRA DE TORSIÓN</b> STABILIZER BAR BUSHING</p> <p><b>200-7150</b> OEM KO66-58, KO66-293, KO66-449</p> 	<p><b>BUJE PARA BARRA DE TORSIÓN POLIURETANO</b> URETHANE STABILIZER BAR BUSHING</p> <p><b>200-7150P</b> OEM KO66-58, KO66-293, KO66-449</p> 
<p>SUSPENSIÓN: KENWORTH AIRGLIDE 200</p> <p>ESPECIFICACIONES DE= 3.120" DI= 2.110" L= 2.930"</p>	<p>SUSPENSIÓN: KENWORTH AIRGLIDE 100</p> <p>ESPECIFICACIONES DE= 2 7/8" DI= 2" L= 4"</p>	<p>SUSPENSIÓN: KENWORTH AIRGLIDE 100</p> <p>ESPECIFICACIONES DE= 2 7/8" DI= 2" L= 4" HD= 80</p>
<p><b>BUJE PARA BARRA ESTABILIZADORA</b> STABILIZER BAR BUSHING</p> <p><b>200-8849</b> OEM KWO88494AC</p> 	<p><b>BUJE PARA BARRA ESTABILIZADORA POLIURETANO</b> URETHANE STABILIZER BAR BUSHING</p> <p><b>200-8849P</b> OEM KWO88494AC</p> 	<p><b>BUJE PARA BARRA ESTABILIZADORA</b> STABILIZER BAR BUSHING</p> <p><b>200-10903</b> OEM 710903, MP710903</p> 
<p>SUSPENSIÓN: KENWORTH AIRGLIDE 400</p> <p>ESPECIFICACIONES DE= 3 7/64" DI= 2 17/64" L= 2 7/8"</p>	<p>SUSPENSIÓN: KENWORTH AIRGLIDE 400</p> <p>ESPECIFICACIONES DE= 3 7/64" DI= 2 17/64" L= 2 7/8" HD= 80</p>	<p>SUSPENSIÓN: AUTOBUS VOLVO</p> <p>ESPECIFICACIONES GROSOR= 2 1/4" ANCHO= 2 3/4" L= 2 3/8" DI= 1 5/8"</p>
<p><b>BUJE PARA BARRA ESTABILIZADORA POLIURETANO</b> URETHANE STABILIZER BAR BUSHING</p> <p><b>200-10903P</b> OEM 710903, MP710903</p> 	<p><b>BUJE PARA MUELLE</b> SPRING RUBBER BUSHING</p> <p><b>200-59259</b> OEM 59259-2</p> 	<p><b>BUJE PARA MUELLE POLIURETANO</b> SPRING URETHANE BUSHING</p> <p><b>200-59259P</b> OEM 59259-2</p> 
<p>SUSPENSIÓN: AUTOBUS VOLVO</p> <p>ESPECIFICACIONES GROSOR= 2 1/4" ANCHO= 2 3/4" L= 2 3/8" DI= 1 5/8" HD= 90</p>	<p>SUSPENSIÓN: HENDRICKSON</p> <p>ESPECIFICACIONES DE= 1 31/32" DI= 13/16" L= 3 1/4"</p>	<p>SUSPENSIÓN: HENDRICKSON</p> <p>ESPECIFICACIONES DE= 1 31/32" DI= 13/16" L= 3 1/4" HD= 80</p>

<b>BUJE PARA MUELLE</b> SPRING RUBBER BUSHING		<b>BUJE PARA MUELLE</b> SPRING RUBBER BUSHING		<b>BUJE PARA VIGA BALANCEADORA</b> BALANCER BEAM BUSHING	
<b>200-7152</b>		<b>200-206017</b>		<b>200-056020</b>	
OEM		OEM		OEM	
					
SUSPENSIÓN:	RENAULT	SUSPENSIÓN:	KENWORTH	SUSPENSIÓN:	MCI TORCILASTICA
<b>ESPECIFICACIONES</b>		<b>ESPECIFICACIONES</b>		<b>ESPECIFICACIONES</b>	
DE= 1 7/8" DI= 5/8" L= 3"		DE= 1 1/16" DI= 1 3/4" L= 4 1/4"		DE 1= 5 1/2" DE 2= 3 3/4" DI= 21/32 L= 3 25/32"	

<b>NÚCLEO PARA TENSOR</b> TORQUE ROD BUSHING		<b>BUJE PARA TENSOR POLIURETANO</b> URETHANE TORQUE ROD BUSHING		<b>BUJE PARA TENSOR POLIURETANO</b> URETHANE TORQUE ROD BUSHING	
<b>200-056026</b>		<b>200-22128P</b>		<b>200-800009P</b>	
OEM		OEM 22128		OEM 800009	
					
SUSPENSIÓN:	MCI TORCILASTICA	SUSPENSIÓN:	CHALMERS SUSP. SERIE 600	SUSPENSIÓN:	CHALMERS SUSP. SERIE 600
<b>ESPECIFICACIONES</b>		<b>ESPECIFICACIONES</b>		<b>ESPECIFICACIONES</b>	
DE= 3 1/2" DB= 21/32" LB= 5 1/8" LC= 2 13/16"		DE = 3 5/8" DI = 2 7/16" ALTO= 1 7/8" HD = 80		DE= 4 1/2" DI= 2 1/2" ALTO= 2 HD= 80	

<b>BUJE PARA TENSOR POLIURETANO</b> URETHANE TORQUE ROD BUSHING		<b>BUJE PARA MUELLE</b> LOWER PAD		<b>BUJE PARA MUELLE POLIURETANO</b> URETHANE LOWER PAD	
<b>200-800010P</b>		<b>200-1615773</b>		<b>200-1615773P</b>	
OEM 800010		OEM		OEM	
					
SUSPENSIÓN:	CHALMERS SUSP. SERIE 600	SUSPENSIÓN:	FREIGHTLINER STERLING	SUSPENSIÓN:	FREIGHTLINER STERLING
<b>ESPECIFICACIONES</b>		<b>ESPECIFICACIONES</b>		<b>ESPECIFICACIONES</b>	
DE= 4 1/4" DI= 2 1/2" ALTO= 2 1/8" HD= 80		ALTO = 5 1/8" ANCHO = 5 1/8" L= 7 1/2"		ALTO = 5 1/8" ANCHO = 5 1/8" L= 7 1/2" HD= 80	

<b>BUJE PARA TENSOR VOLKSWAGEN</b> TORQUE ROD BUSHING		<b>BUJE PARA TENSOR VOLKSWAGEN POLIURETANO</b> URETHANE TORQUE ROD BUSHING		<b>SOPORTE INFERIOR PARA SUSPENSIÓN POLIURETANO ALTO IMPACTO</b> URETHANE LOWER INSULATOR PAD	
<b>200-4567890</b>		<b>200-4567890P</b>		<b>200-10QK36BP</b>	
OEM		OEM		OEM 10QK36B	
					
SUSPENSIÓN:	VOLKSWAGEN	SUSPENSIÓN:	VOLKSWAGEN	SUSPENSIÓN:	MACK
<b>ESPECIFICACIONES</b>		<b>ESPECIFICACIONES</b>		<b>ESPECIFICACIONES</b>	
DI= 31/32" DE= 2 1/4" LARGO = 2 1/2"		DI= 31/32" DE= 2 1/4" LARGO = 2 1/2" HD= 80		ANCHO= 6 15/16" ESPESOR= 3 13/16" LARGO= 7 1/8" HD= 80	

<b>SOPORTE SUPERIOR PARA SUSPENSIÓN</b> <b>POLIURETANO ALTO IMPACTO</b> URETHANE INSULATOR PAD		<b>SOPORTE SUPERIOR PARA SUSPENSIÓN</b> <b>POLIURETANO ALTO IMPACTO</b> URETHANE UPPER INSULATOR PAD		<b>SOPORTE INFERIOR PARA SUSPENSIÓN</b> <b>POLIURETANO ALTO IMPACTO</b> URETHANE LOWER INSULATOR PAD	
<b>200-10QK365AP</b> OEM 10QK365A		<b>200-10QK370P</b> OEM 10QK370		<b>200-10QK372P</b> OEM 10QK372	
					
SUSPENSIÓN:	MACK	SUSPENSIÓN:	MACK	SUSPENSIÓN:	MACK
<b>ESPECIFICACIONES</b> ANCHO= 5 5/12" ESPESOR= 2 5/16" LARGO= 6 5/8" HD= 80		<b>ESPECIFICACIONES</b> ANCHO= 5" ESPESOR= 3 15/32" LARGO= 6 15/32" HD= 80		<b>ESPECIFICACIONES</b> ANCHO= 7 5/8" ESPESOR= 3 27/32" LARGO= 8" HD= 80	

**PARBO** M.R.

PARTES PARA SUSPENSIÓN

*PARA UN MANEJO SUAVE®*

**E4-340/360/380/400  
FOUR SPRING SUSPENSION**

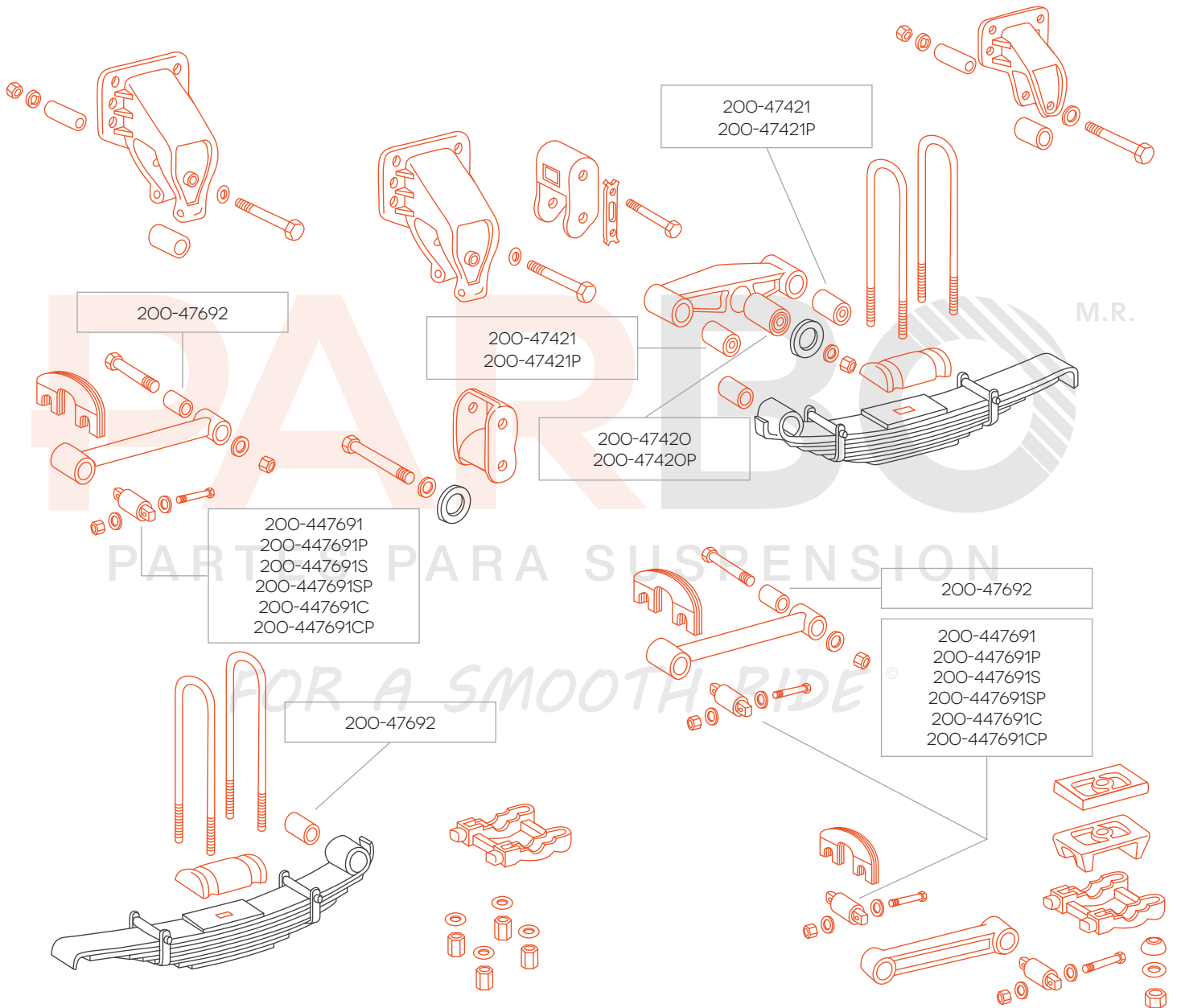

CONSULTE MÁS DIAGRAMAS DE SUSPENSIÓN EN NUESTRO SITIO WEB: [WWW.PARBO.COM.MX](http://WWW.PARBO.COM.MX)



RT/RTE 380/400/440/460  
RT2/RTE2 400/460  
TANDEM SUSPENSIONS

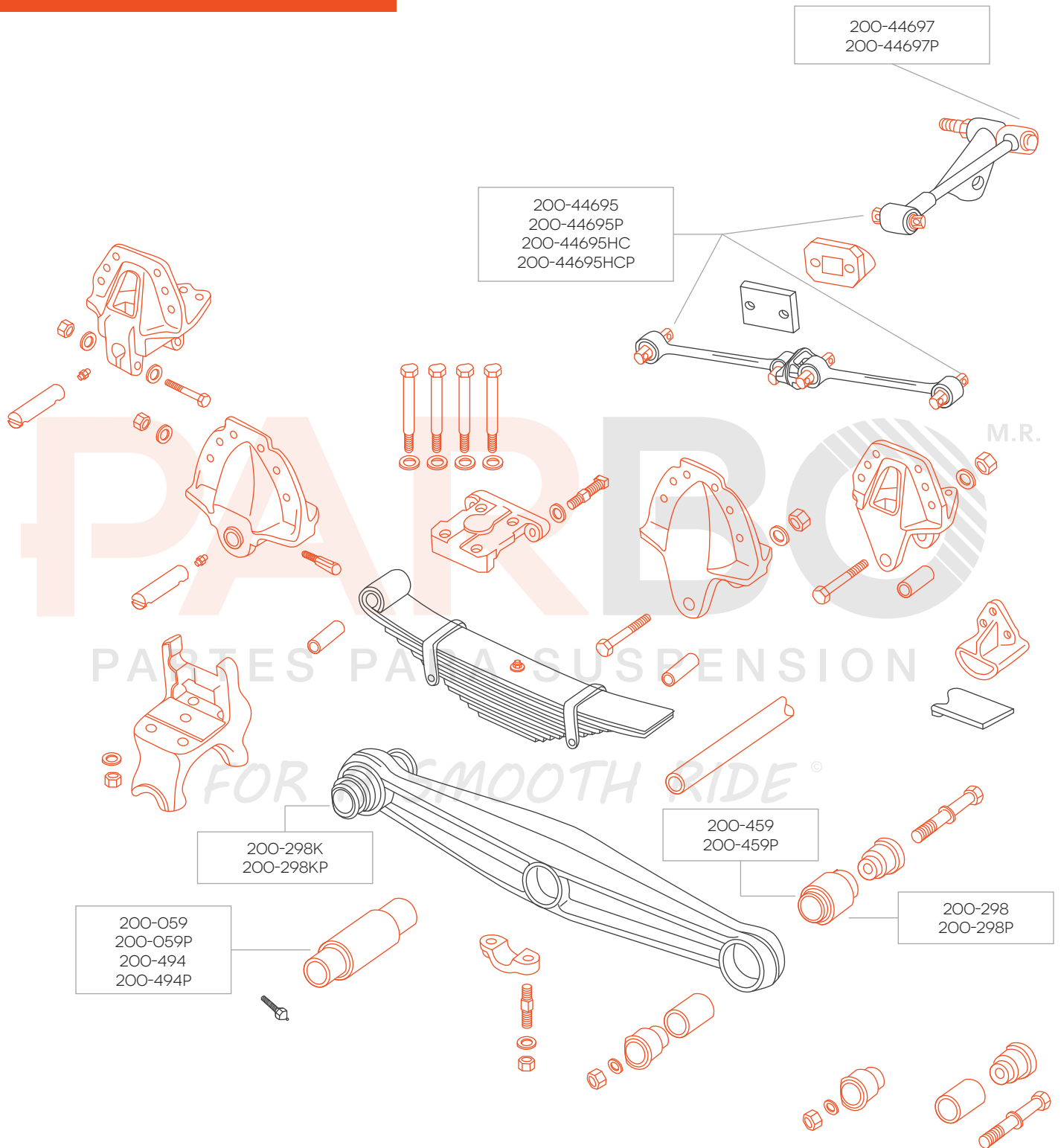

CONSULTE MÁS DIAGRAMAS DE SUSPENSION EN NUESTRO SITIO WEB: [WWW.PARBO.COM.MX](http://WWW.PARBO.COM.MX)

HN400/460 (3/96 TO 9/97)  
HN402/462/522 (4/96 TO PRESENT)  
BOLSTER SPRING SUSPENSIONS

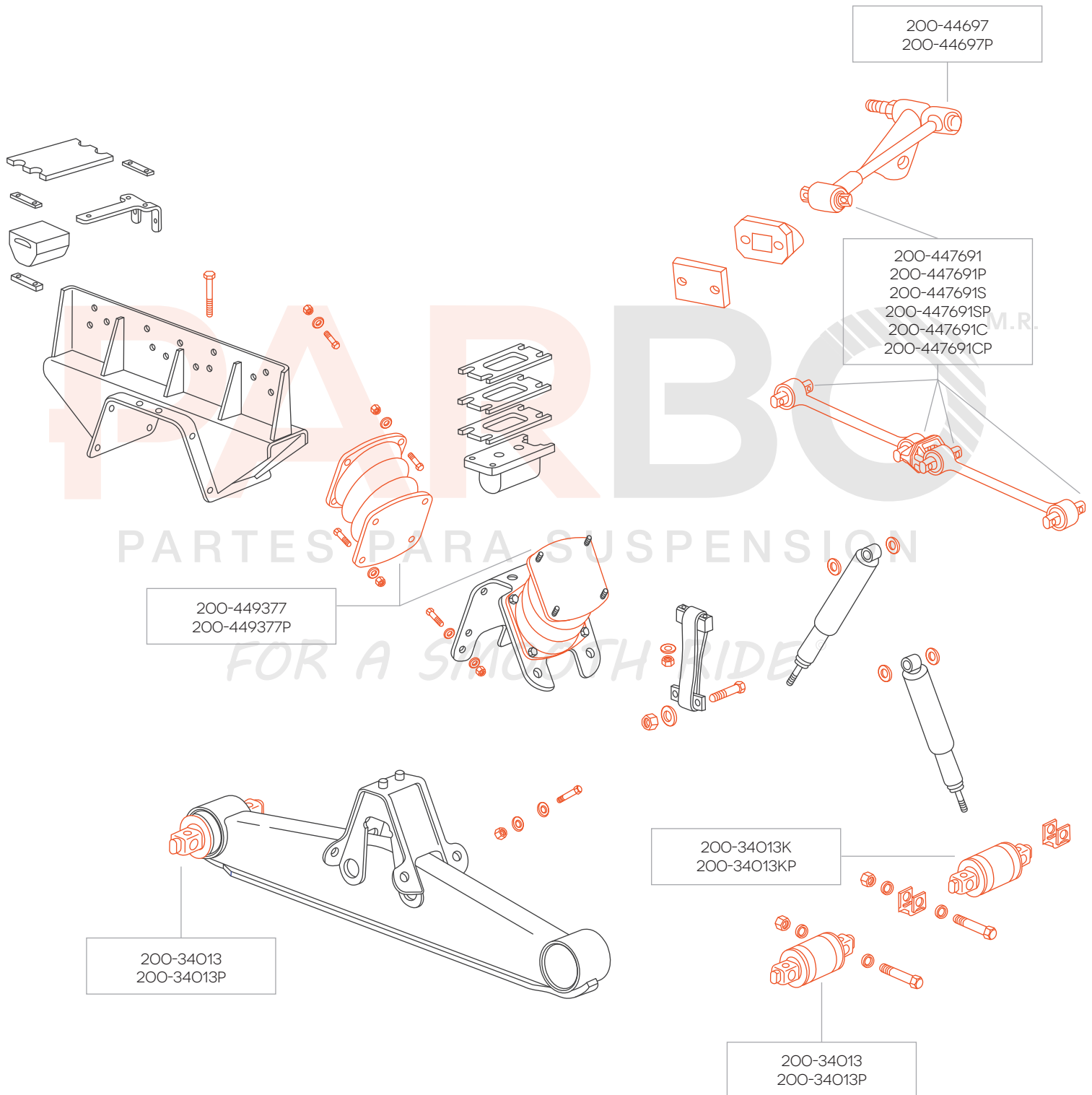

CONSULTE MÁS DIAGRAMAS DE SUSPENSION EN NUESTRO SITIO WEB: [WWW.PARBO.COM.MX](http://WWW.PARBO.COM.MX)

HA180/200/230  
HA360/400/460  
SINGLE/TANDEM AXLE AIR SUSPENSIONS

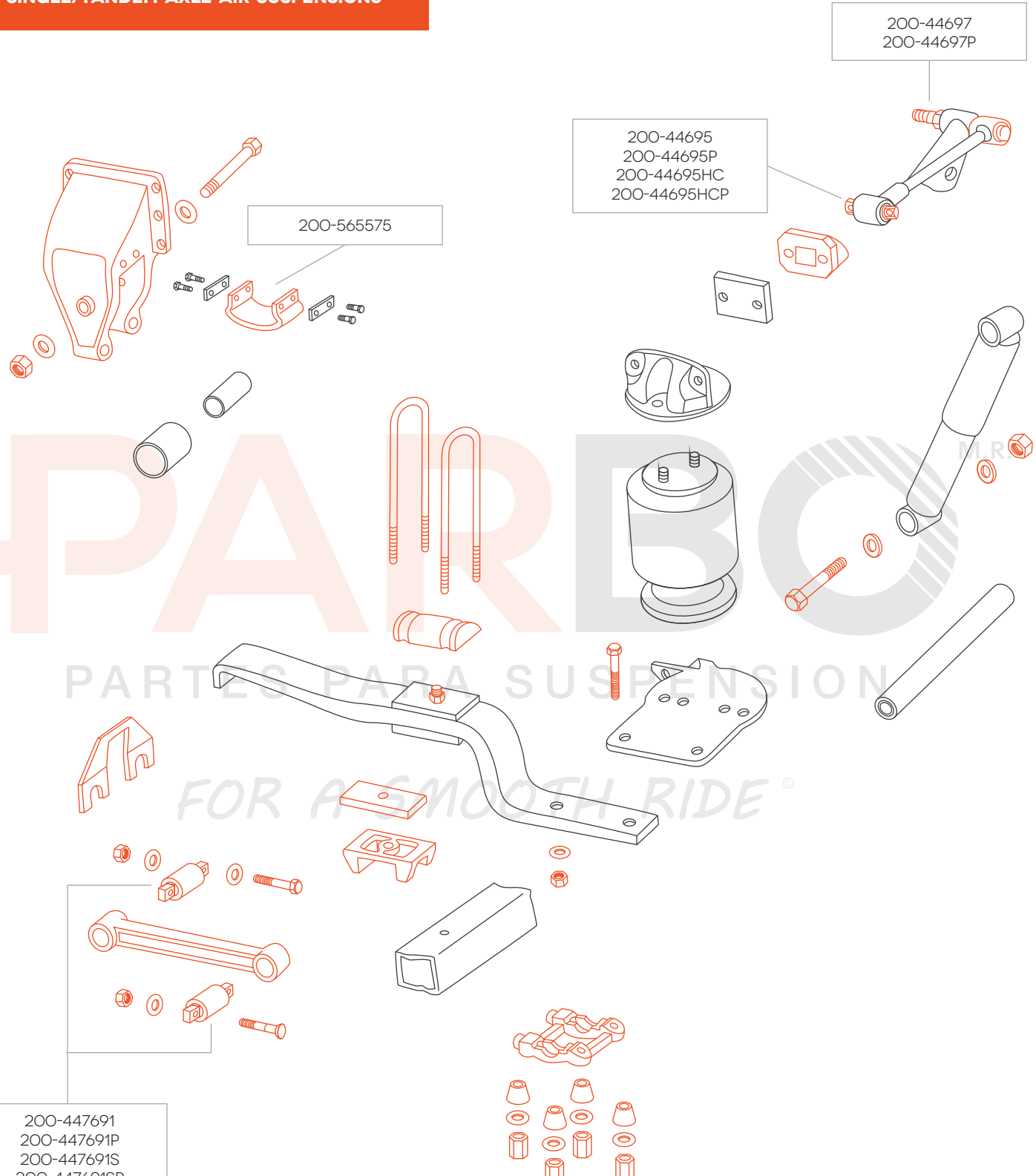

200-44697  
200-44697P

200-44695  
200-44695P  
200-44695HC  
200-44695HCP

200-565575

200-447691  
200-447691P  
200-447691S  
200-447691SP  
200-447691C  
200-447691CP  
200-44695  
200-44695P  
200-44695HC  
200-44695HCP  
200-57256  
200-57256P

CONSULTE MÁS DIAGRAMAS DE SUSPENSION EN NUESTRO SITIO WEB: [WWW.PARBO.COM.MX](http://WWW.PARBO.COM.MX)

HAS120/150/230  
HAS360/400/40LH/460  
SINGLE/TANDEM AXLE AIR SUSPENSIONS

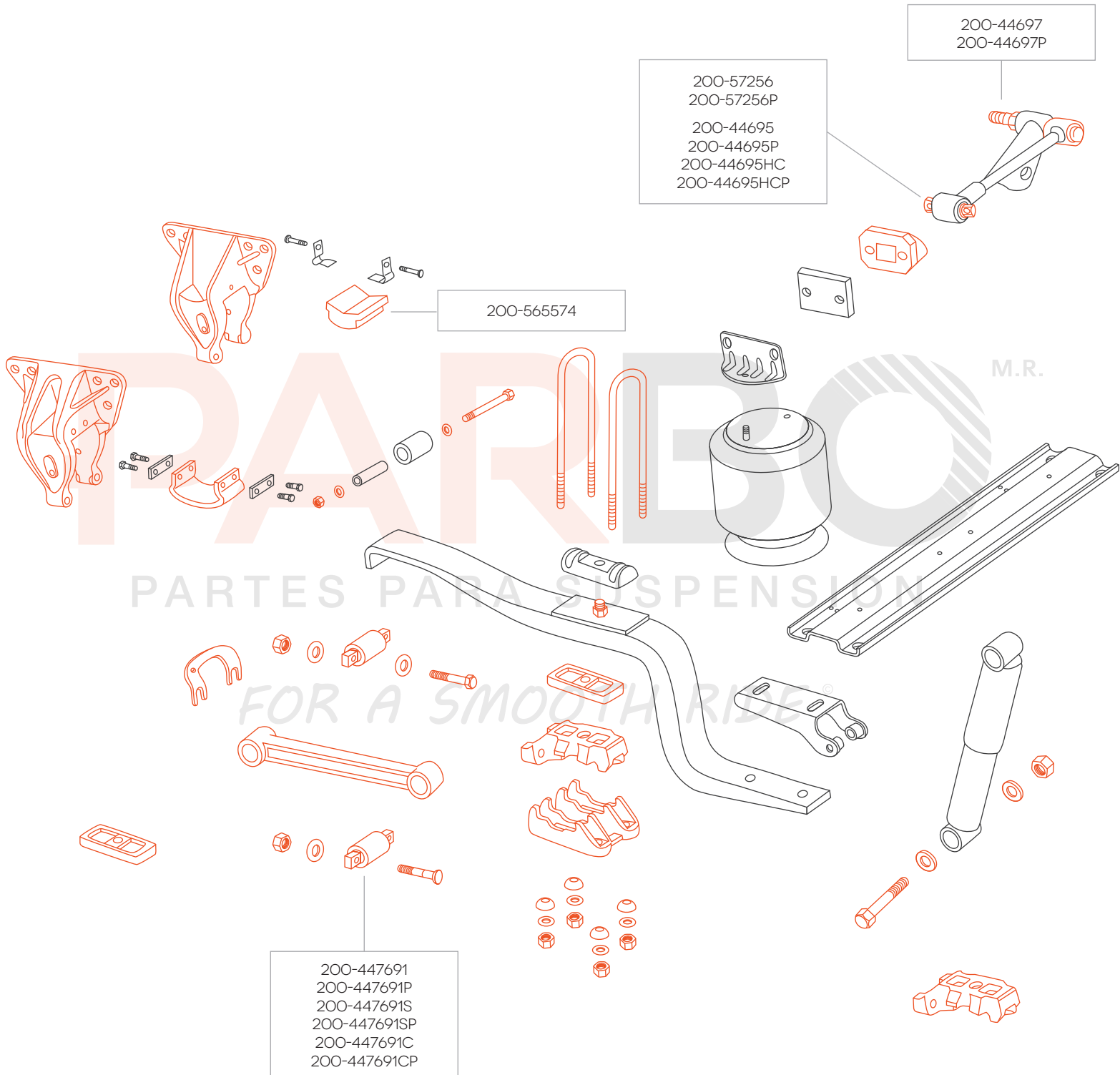

CONSULTE MÁS DIAGRAMAS DE SUSPENSION EN NUESTRO SITIO WEB: [WWW.PARBO.COM.MX](http://WWW.PARBO.COM.MX)

HK/HS 190/230  
H190/230/250/300 (All)  
AIR SUSPENSIONS

200-3558  
200-6914  
200-6914QA  
200-3558P  
200-6914P  
200-6914QAP

M.R.

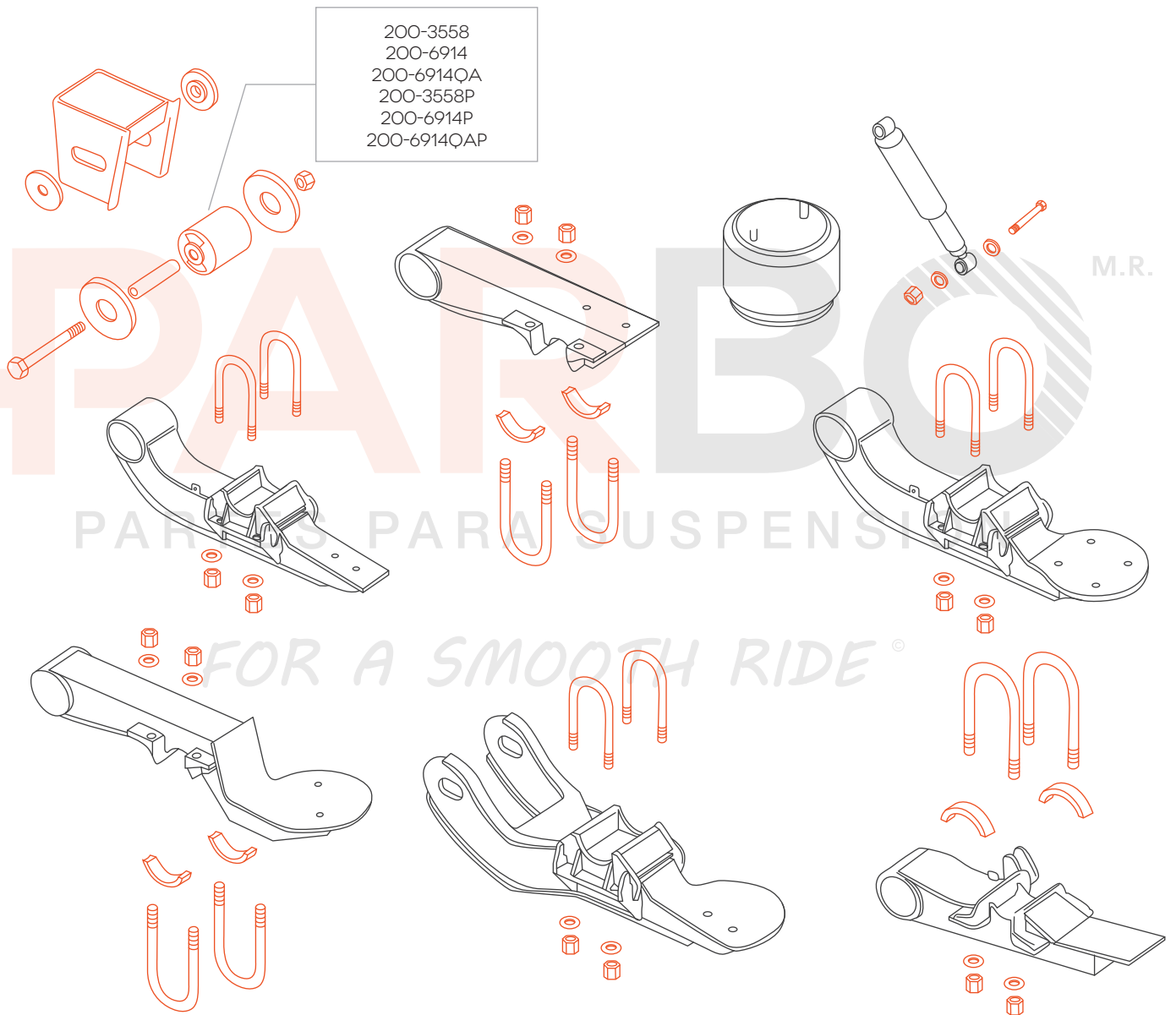

CONSULTE MÁS DIAGRAMAS DE SUSPENSIÓN EN NUESTRO SITIO WEB: [WWW.PARBO.COM.MX](http://WWW.PARBO.COM.MX)

C500, K100/300, W900  
T300/400/450/600/800  
FRONT SUSPENSIONS

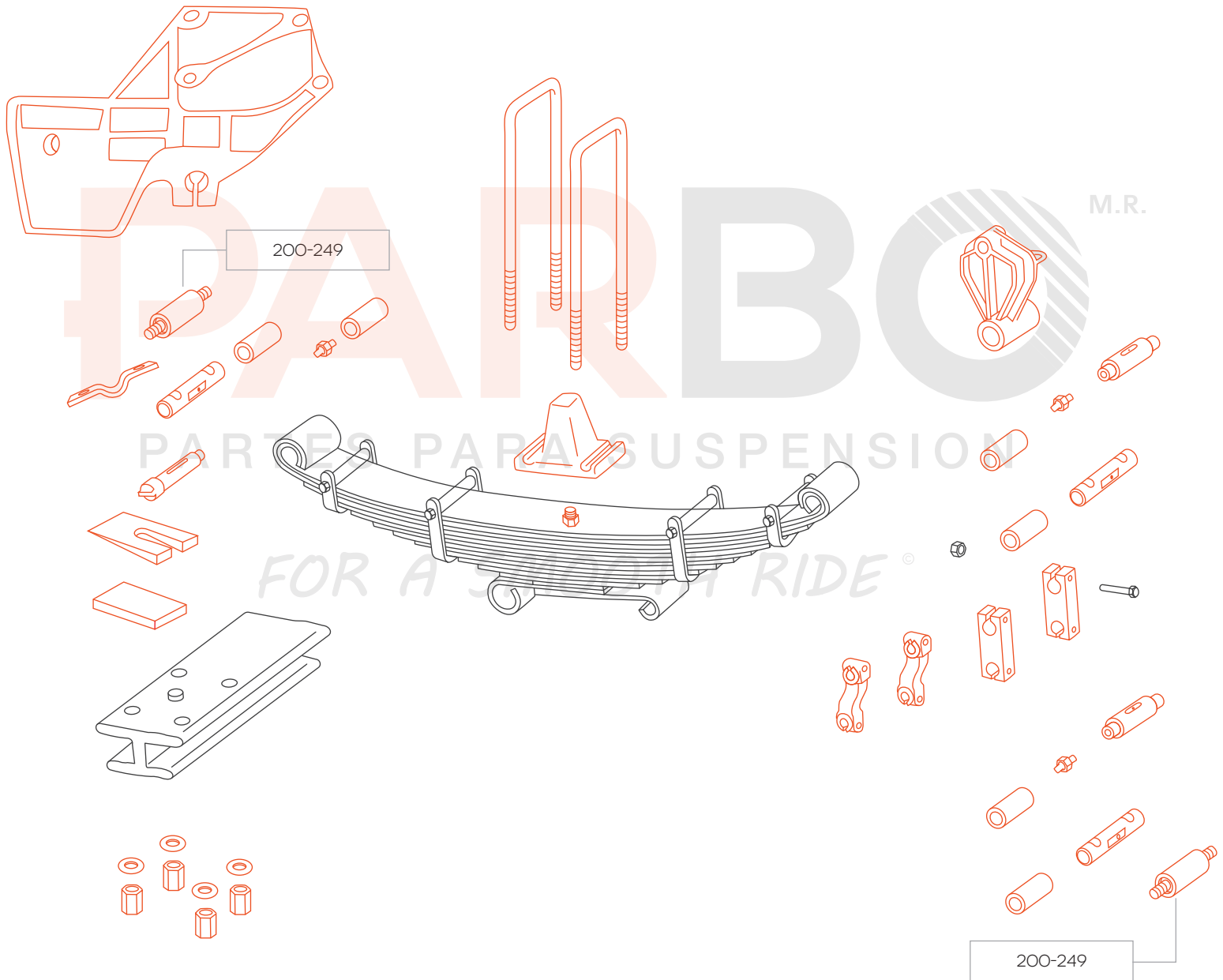

CONSULTE MÁS DIAGRAMAS DE SUSPENSIÓN EN NUESTRO SITIO WEB: [WWW.PARBO.COM.MX](http://WWW.PARBO.COM.MX)

**"BIG 6"  
(KW6-50)  
REAR SUSPENSIONS**

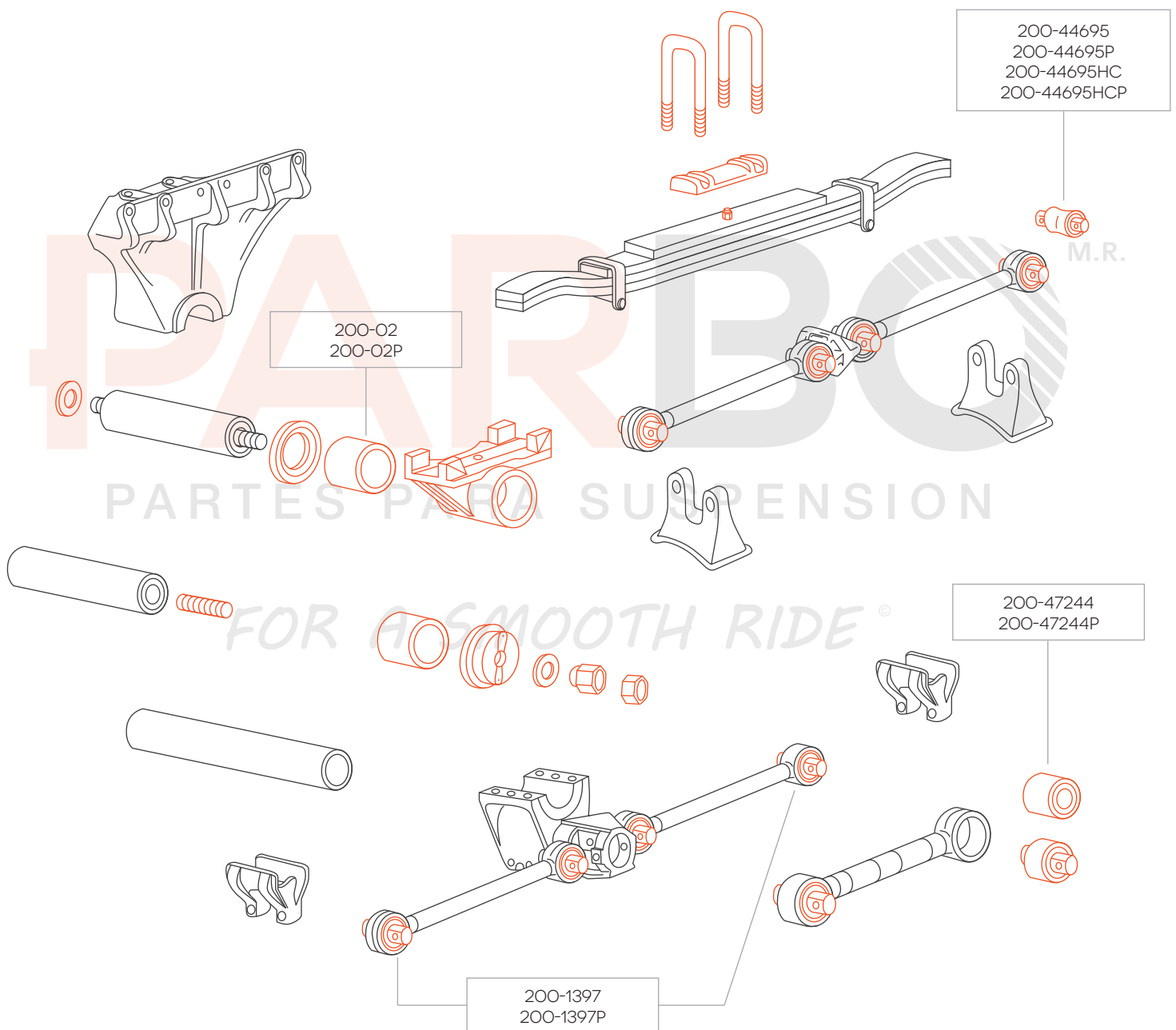

CONSULTE MÁS DIAGRAMAS DE SUSPENSIÓN EN NUESTRO SITIO WEB: [WWW.PARBO.COM.MX](http://WWW.PARBO.COM.MX)

**AIRGLIDE 100  
AIR SUSPENSION**

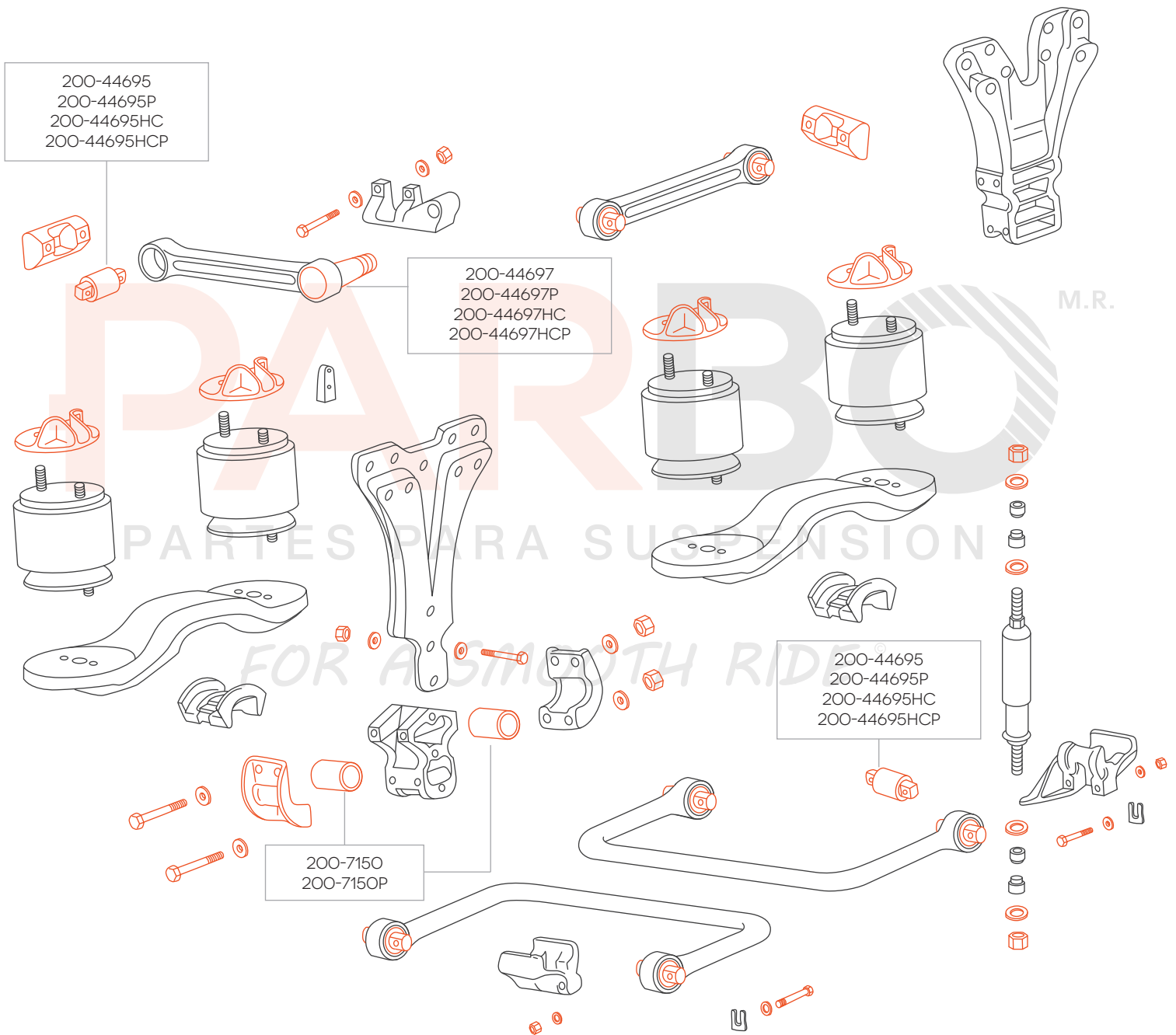

CONSULTE MÁS DIAGRAMAS DE SUSPENSIÓN EN NUESTRO SITIO WEB: [WWW.PARBO.COM.MX](http://WWW.PARBO.COM.MX)



**AIRGLIDE 200  
AIR SUSPENSION**

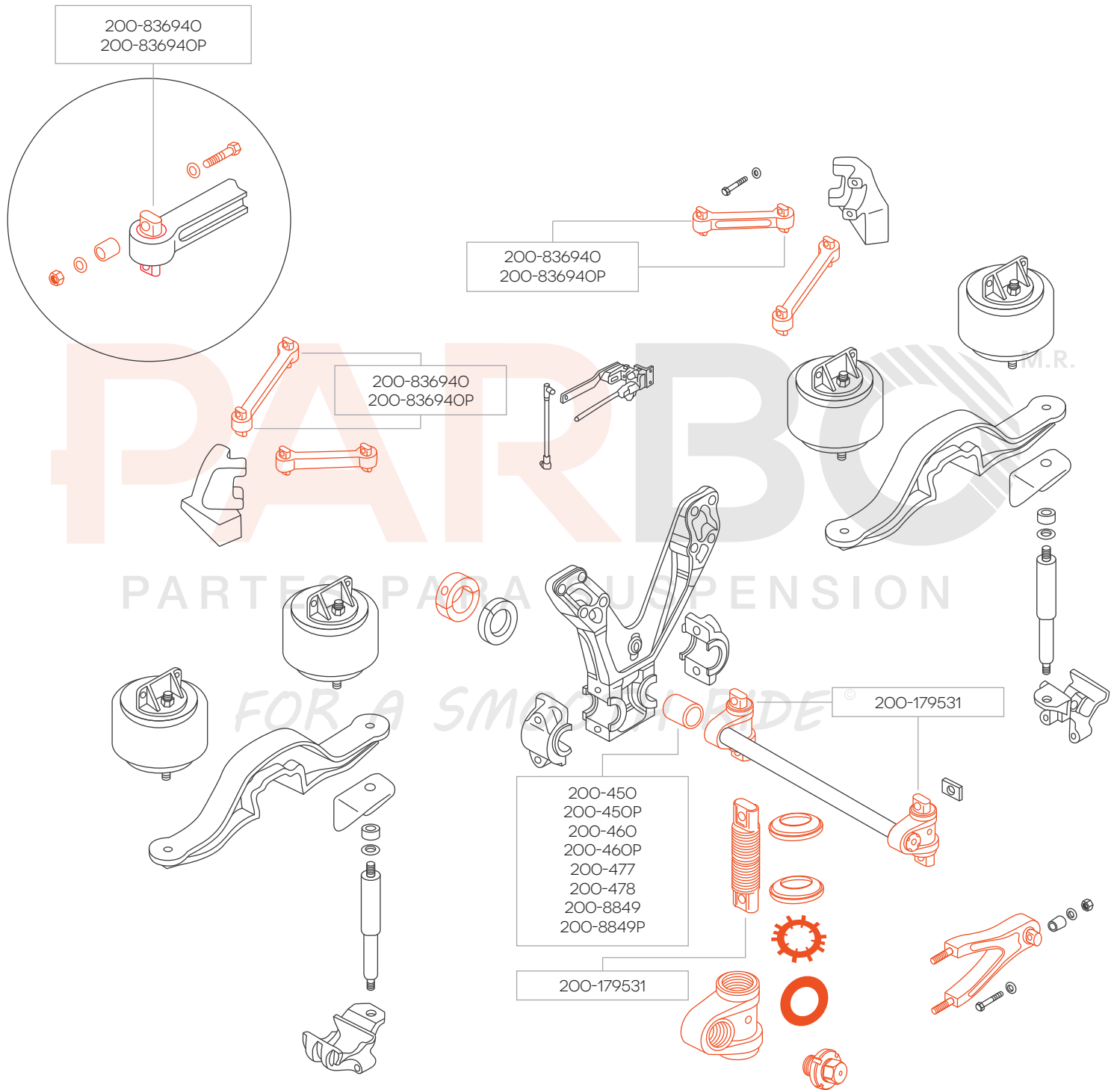

CONSULTE MÁS DIAGRAMAS DE SUSPENSION EN NUESTRO SITIO WEB: [WWW.PARBO.COM.MX](http://WWW.PARBO.COM.MX)

CH/CL600 SERIES  
FRONT SUSPENSIONS

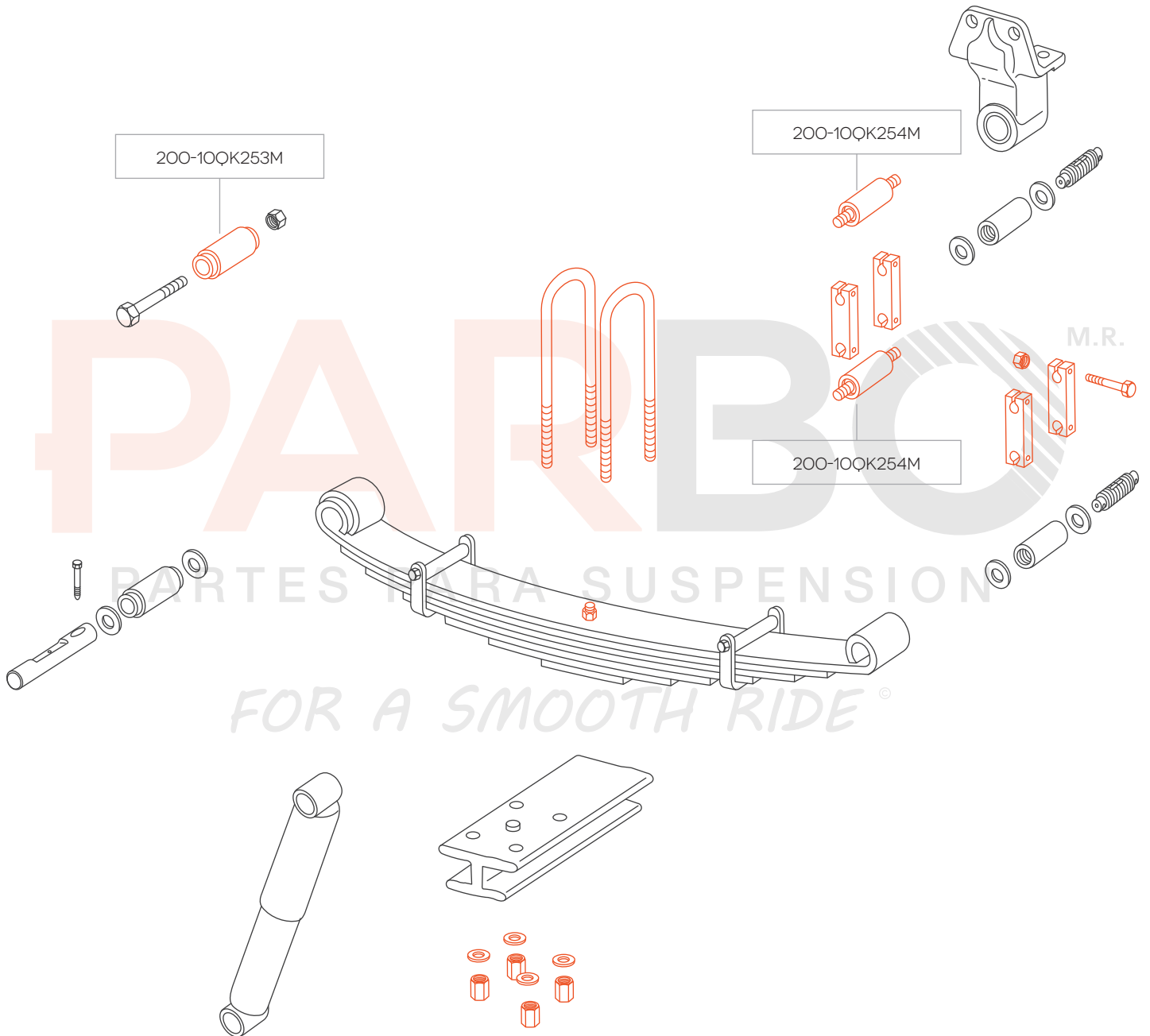

CONSULTE MÁS DIAGRAMAS DE SUSPENSION EN NUESTRO SITIO WEB: [WWW.PARBO.COM.MX](http://WWW.PARBO.COM.MX)

**SS34/38 CAMELBACK  
( 4" SPRING, TWO PIECE TRUNNION )  
REAR SUSPENSIONS**

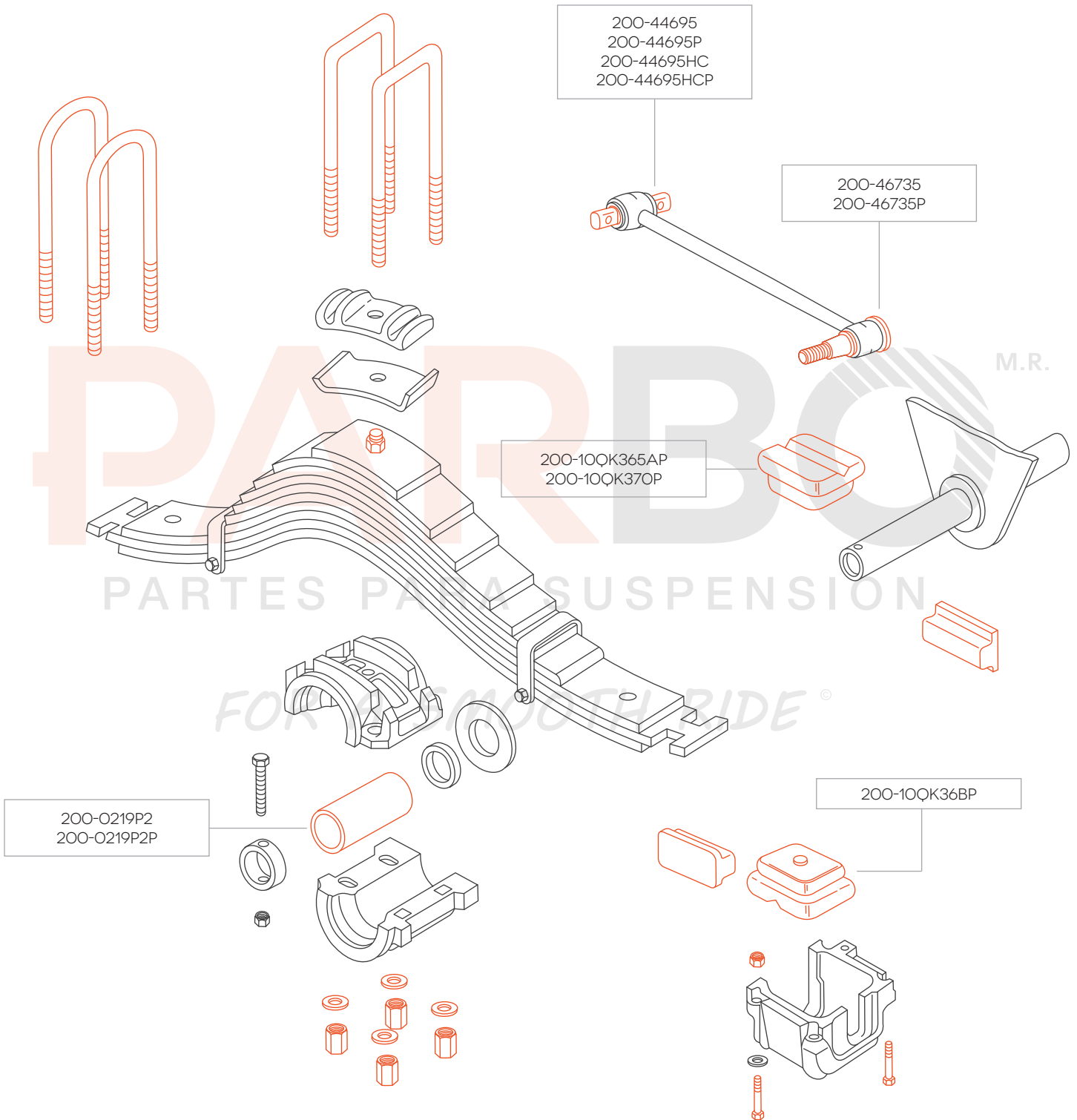

CONSULTE MÁS DIAGRAMAS DE SUSPENSION EN NUESTRO SITIO WEB: [WWW.PARBO.COM.MX](http://WWW.PARBO.COM.MX)

**CORPORATE AIR SUSPENSION  
REAR SINGLE/TANDEM AXLE  
"Z" BEAM**

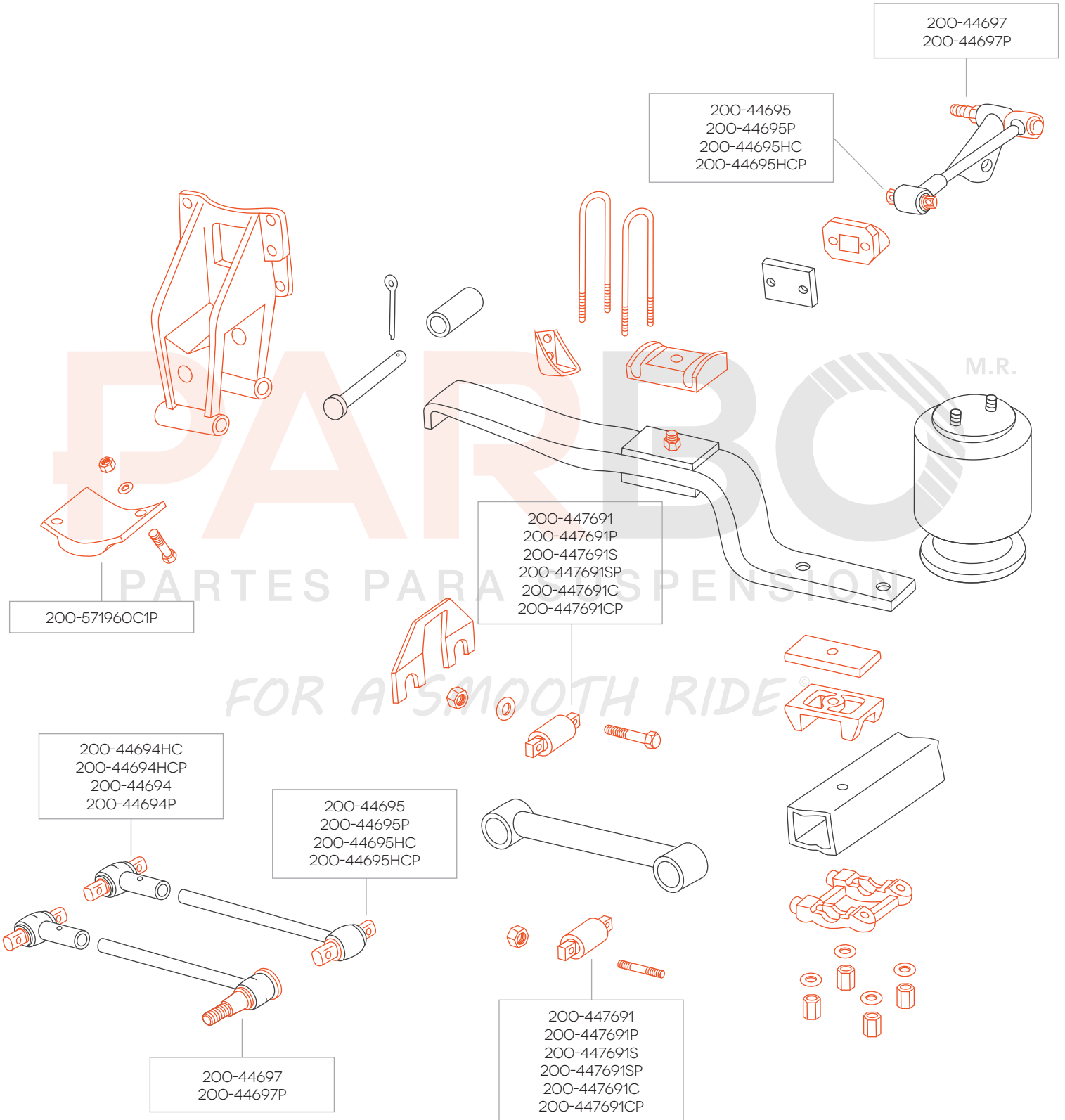

CONSULTE MÁS DIAGRAMAS DE SUSPENSION EN NUESTRO SITIO WEB: [WWW.PARBO.COM.MX](http://WWW.PARBO.COM.MX)

**CORPORATE FOUR SPRING  
REAR TANDEM SUSPENSION  
(8100/9200 SINGLE AXLE)**

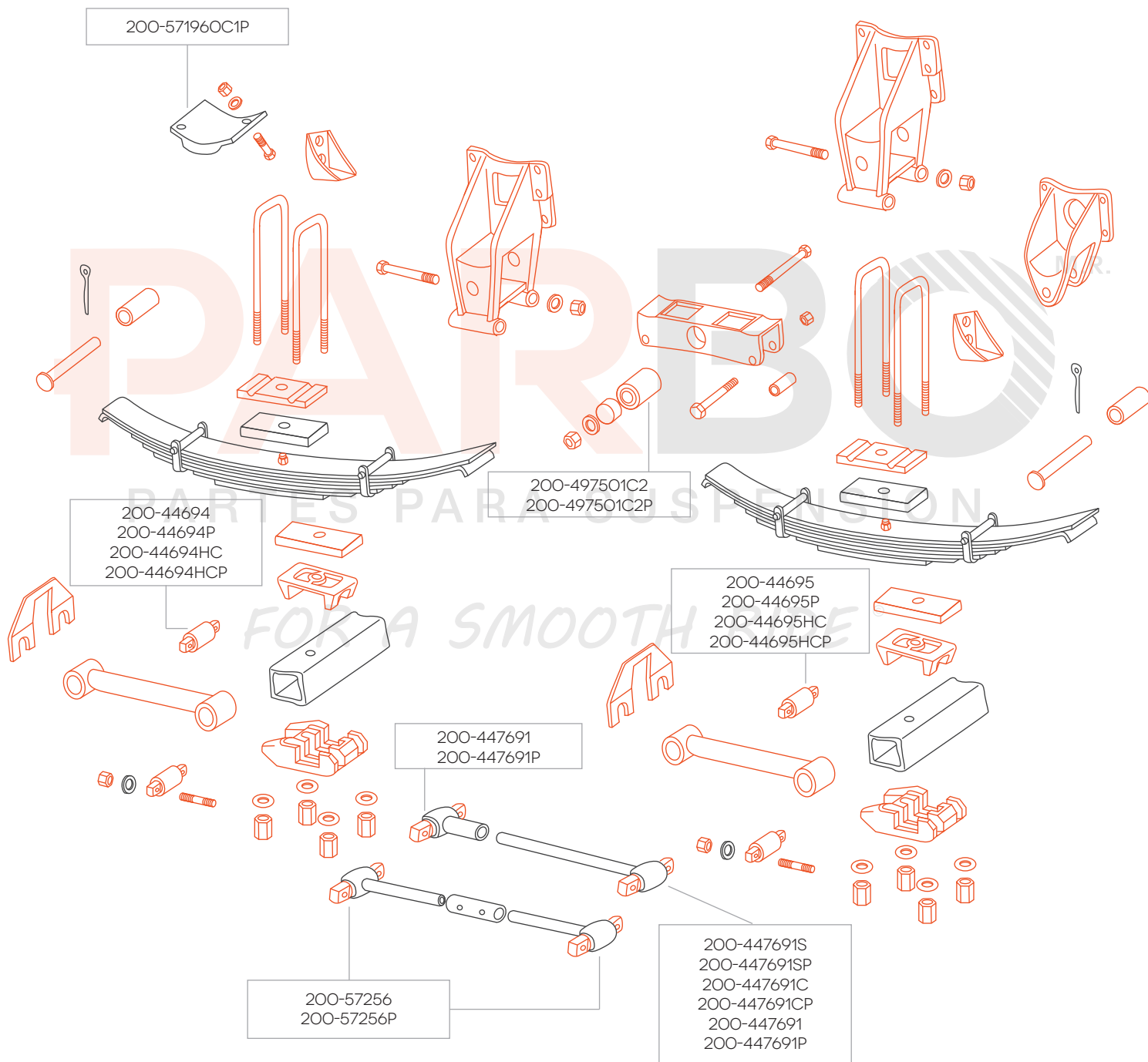

CONSULTE MÁS DIAGRAMAS DE SUSPENSION EN NUESTRO SITIO WEB: [WWW.PARBO.COM.MX](http://WWW.PARBO.COM.MX)

9200/9400 CONVENTIONAL  
9600/9700 CAB OVER  
FRONT SUSPENSIONS

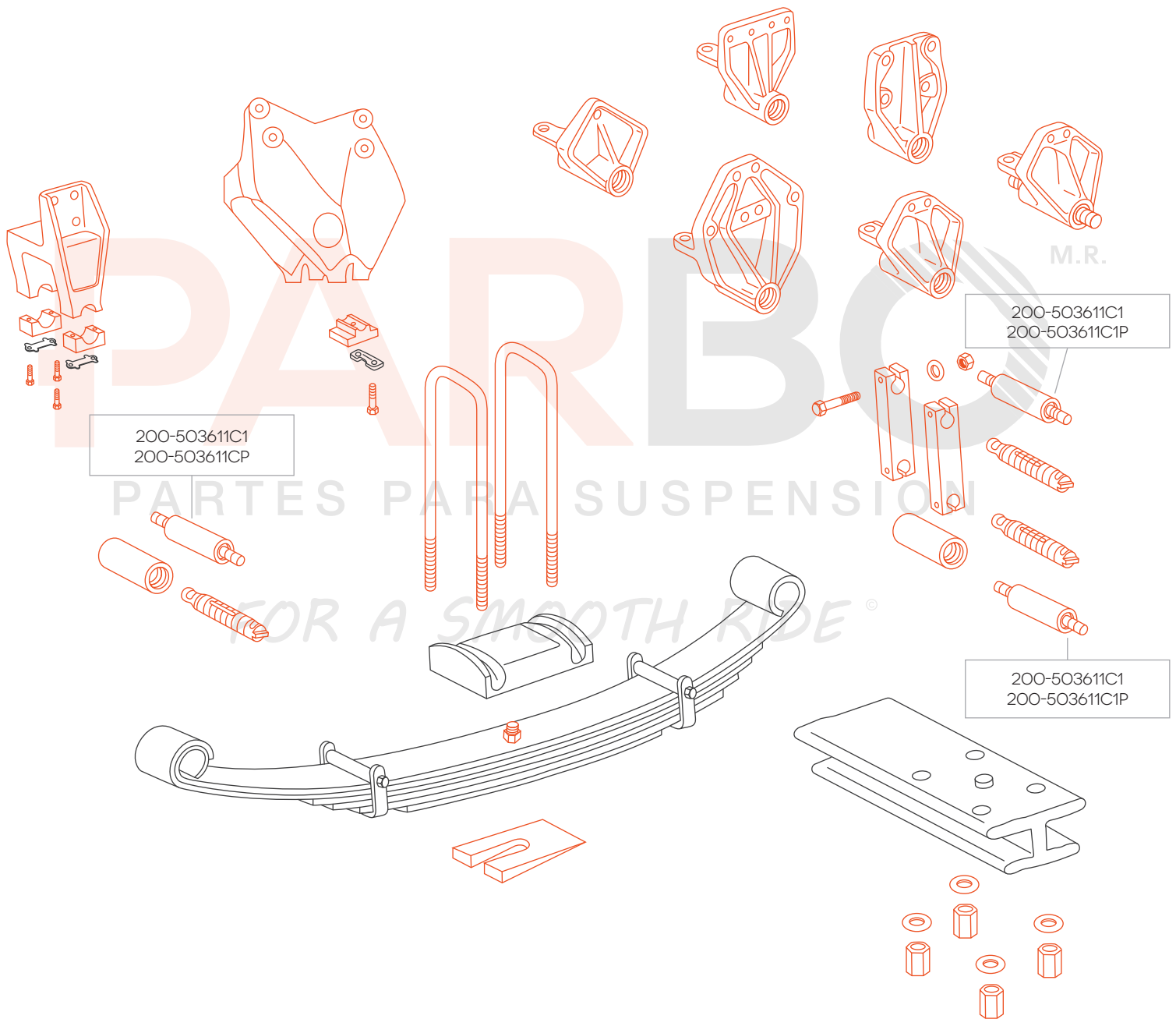

CONSULTE MÁS DIAGRAMAS DE SUSPENSIÓN EN NUESTRO SITIO WEB: [WWW.PARBO.COM.MX](http://WWW.PARBO.COM.MX)

FAS II AIRLINER (CURRENT PRODUCTION)  
SINGLE/TANDEM AXLE  
AIR SUSPENSION

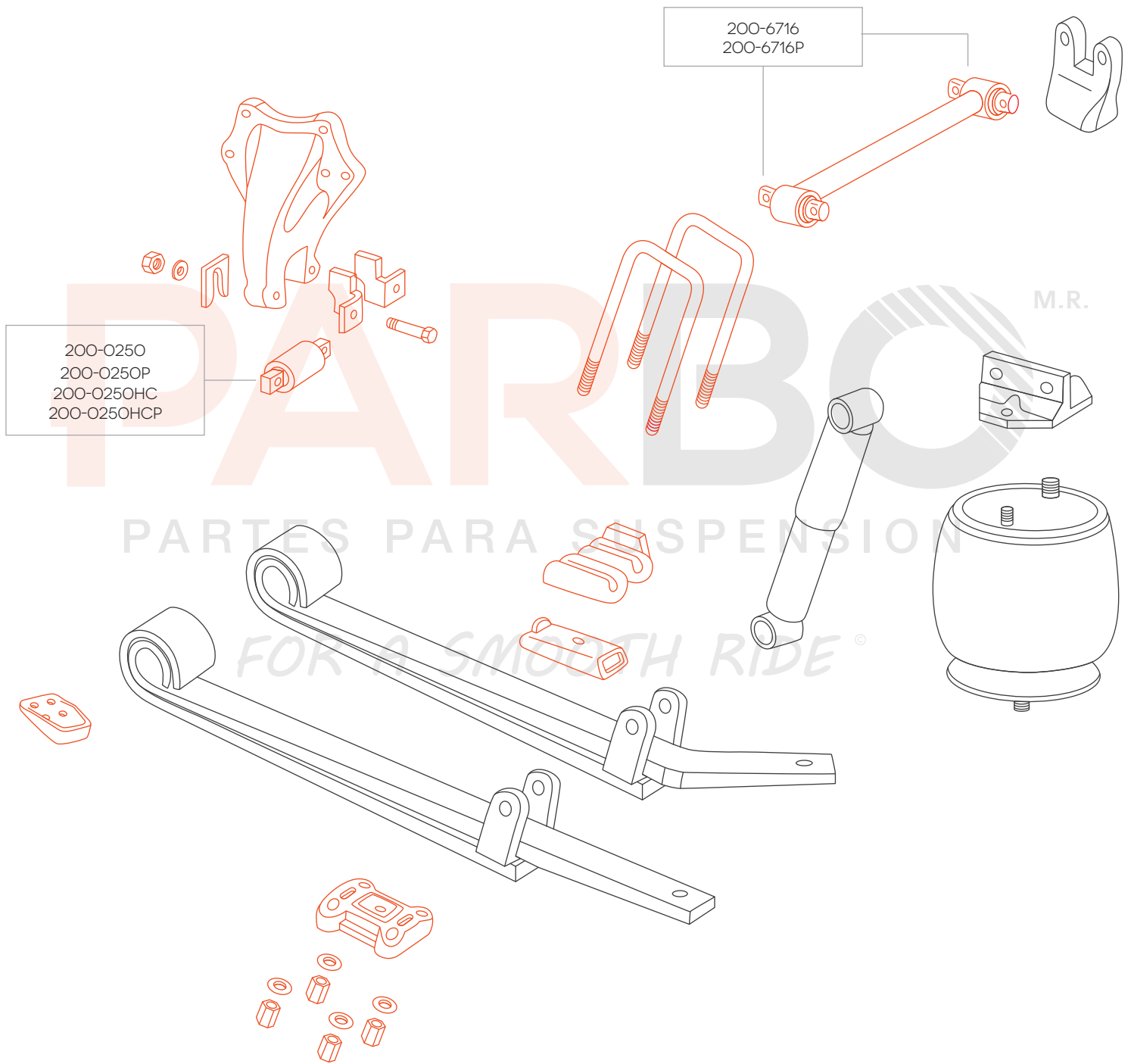

CONSULTE MÁS DIAGRAMAS DE SUSPENSIÓN EN NUESTRO SITIO WEB: [WWW.PARBO.COM.MX](http://WWW.PARBO.COM.MX)

**PARBO** M.R.

PARTES PARA SUSPENSION

*PARA UN MANEJO SUAVE®*



# GANCHOS Y GUÍAS PARA COFRE HOODS, PINS AND HOOKS

**PARBO**<sup>M.R.</sup>  
PARTES PARA SUSPENSION  
*PARA UN MANEJO SUAVE*

<b>GUÍA PARA COFRE</b> HOOD LOCATING PIN	<b>GUÍA PARA COFRE POLIURETANO</b> URETHANE HOOD LOCATING PIN	<b>BASE Y GUÍA PARA COFRE</b> HOOD PIN AND BASE
<b>PBC-1001</b> OEM K179-450,25QM31	<b>PBC-1001P</b> OEM K179-450,25QM31	<b>PBC-1002 CH Y G</b> OEM
		
<b>SUSPENSIÓN:</b> MACK, KENWORTH W-900, T-600 Y T-800	<b>SUSPENSIÓN:</b> MACK, KENWORTH W-900, T-600 Y T-800	<b>SUSPENSIÓN:</b> PBC-1002 - CH PARA KW W-900 PBC-1002 - G PARA KW T-600 Y T-800
<b>ESPECIFICACIONES</b> A= 4" D1= 1 1/2" D2= 3 3/16"	<b>ESPECIFICACIONES</b> A= 4" D1= 1 1/2" D2= 3 3/16" HD= 80	<b>ESPECIFICACIONES</b>

<b>BASE Y GUÍA PARA COFRE POLIURETANO</b> URETHANE HOOD PIN AND BASE	<b>BASE PARA GUÍA DE COFRE</b> BASE FOR HOOD PIN	<b>GUÍA PARA COFRE</b> HOOD PIN
<b>PBC-1002 CHP Y GP</b>	<b>PBC-1003 CH Y G</b> OEM CH:K179-375 G:K179-481	<b>PBC-1004</b> OEM A17-10464-001
		
<b>SUSPENSIÓN:</b> PBC-1002 - CHP PARA KW W-900 PBC-1002 - GP PARA KW T-600 Y T-800	<b>SUSPENSIÓN:</b> PBC-1003 - CH PARA KW W-900 PBC-1003 - G PARA KW T-600 Y T-800	<b>SUSPENSIÓN:</b> FREIGHTLINER
<b>ESPECIFICACIONES</b>	<b>ESPECIFICACIONES</b>	<b>ESPECIFICACIONES</b> A= 2 7/8" DE= 4" DI= 1/2"

<b>GUÍA PARA COFRE POLIURETANO</b> URETHANE HOOD PIN	<b>GUÍA PARA COFRE</b> HOOD GUIDE	<b>GUÍA PARA COFRE POLIURETANO</b> URETHANE HOOD GUIDE
<b>PBC-1004P</b> OEM A17-10464-001	<b>PBC-13666</b> OEM A17-13666-000	<b>PBC-13666P</b> OEM A17-13666-000
		
<b>SUSPENSIÓN:</b> FREIGHTLINER	<b>SUSPENSIÓN:</b> FREIGHTLINER COLUMBIA	<b>SUSPENSIÓN:</b> FREIGHTLINER COLUMBIA
<b>ESPECIFICACIONES</b> A= 2 7/8" DE= 4" DI= 1/2" HD= 80	<b>ESPECIFICACIONES</b> DB=7/16" LARGO=3 7/16" ANCHO= 1 11/16"	<b>ESPECIFICACIONES</b> DB=7/16" LARGO=3 7/16" ANCHO= 1 11/16" HD = 80

<b>GUÍA PARA COFRE</b> HOOD PIN	<b>GUÍA PARA COFRE POLIURETANO</b> URETHANE HOOD PIN	<b>GANCHO PARA COFRE</b> HOOD HOOK
<b>PBC-1012</b> OEM 472697C1	<b>PBC-1012P</b> OEM 472697C1	<b>PBC-1005</b> OEM K147-107
		
<b>SUSPENSIÓN:</b> DINA E INTERNATIONAL	<b>SUSPENSIÓN:</b> DINA E INTERNATIONAL	<b>SUSPENSIÓN:</b> KENWORTH
<b>ESPECIFICACIONES</b> DE= 2 3/16" L= 2 1/16" CUERDA= 3/8"	<b>ESPECIFICACIONES</b> DE= 2 3/16" L= 2 1/16" CUERDA= 3/8" HD=80	<b>ESPECIFICACIONES</b> L= 8"

<p><b>GANCHO PARA CAJA DE ACUMULADOR</b> BATTERY HOOK</p> <p><b>PBC-1006</b></p> <p>OEM</p>  <p>SUSPENSIÓN: ACUMULADOR EN GENERAL</p> <p>ESPECIFICACIONES L= 5"</p>	<p><b>GANCHO PARA COFRE</b> HOOD HOOK</p> <p><b>PBC-1007</b></p> <p>OEM K147-842</p>  <p>SUSPENSIÓN: KENWORTH, DNA</p> <p>ESPECIFICACIONES L= 5 13/16"</p>	<p><b>GANCHO PARA COFRE</b> HOOD HOOK</p> <p><b>PBC-1008</b></p> <p>OEM</p>  <p>SUSPENSIÓN: DINA E INTERNACIONAL</p> <p>ESPECIFICACIONES L= 10 1/2"</p>
<p><b>GANCHO PARA COFRE</b> HOOD HOOK</p> <p><b>PBC-1008K</b></p> <p>OEM</p>  <p>SUSPENSIÓN: DINA E INTERNACIONAL</p> <p>ESPECIFICACIONES 1-PBC-1008 2-SOPORTES</p>	<p><b>GANCHO PARA COFRE</b> HOOD HOOK</p> <p><b>PBC-1009</b></p> <p>OEM</p>  <p>SUSPENSIÓN: FREIGHTLINER, VOLVO</p> <p>ESPECIFICACIONES L= 11 1/4"</p>	<p><b>GANCHO PARA COFRE</b> HOOD HOOK</p> <p><b>PBC-1013</b></p> <p>OEM</p>  <p>SUSPENSIÓN: KENWORTH</p> <p>ESPECIFICACIONES LARGO= 10 3/4"</p>
<p><b>BANDERÍN DE SEÑALAMIENTO POLIURETANO</b> URETHANE FLAG</p> <p><b>PBC-1010P</b></p> <p>OEM</p>  <p>SUSPENSIÓN: UNIVERSAL</p> <p>ESPECIFICACIONES D VASTAGO= 5/8" ESPESOR= 1/8" VASTAGO RECTO L= 16" HD= 80</p>	<p><b>BANDERÍN DE SEÑALAMIENTO POLIURETANO</b> URETHANE FLAG</p> <p><b>PBC-1011P</b></p> <p>OEM</p>  <p>SUSPENSIÓN: UNIVERSAL</p> <p>ESPECIFICACIONES D VASTAGO= 5/8" ESPESOR= 1/8" VASTAGO FORMADO L= 16" HD= 80</p>	<p><b>SOPORTE PARA CABINA</b> CAB MOUNT</p> <p><b>PBC-10133</b></p> <p>OEM</p>  <p>SUSPENSIÓN: KENWORTH CONTRA DE PBC-1069</p> <p>ESPECIFICACIONES A= 7/8" DE= 2 15/16" DI= 5/8"</p>
<p><b>SOPORTE UNIVERSAL PARA RADIADOR</b> RADIATOR MOUNT</p> <p><b>PBC-10174</b></p> <p>OEM</p>  <p>SUSPENSIÓN:</p> <p>ESPECIFICACIONES A= 1 15/32" DE 1= 3/4" DE 2= 1 1/4" DI= 7/16"</p>	<p><b>SOPORTE PARA RADIADOR</b> RADIATOR MOUNT</p> <p><b>PBC-10175</b></p> <p>OEM M-200</p>  <p>SUSPENSIÓN: KENWORTH</p> <p>ESPECIFICACIONES A= 7/8" DE 1= 25/32" DE 2= 1 1/8" DI= 3/8"</p>	<p><b>SOPORTE PARA CABINA, RADIADOR</b> RADIATOR AND CAB MOUNT</p> <p><b>PBC-10176</b></p> <p>OEM X-066-176, M-600,476869C1</p>  <p>SUSPENSIÓN: KENWORTH T-800 INTERNATIONAL / NAVISTAR</p> <p>ESPECIFICACIONES A= 2 5/16" DE 1= 1 13/16" DE 2= 3" DI= 5/8"</p>

<b>SOPORTE PARA CABINA, RADIADOR POLIURETANO</b> URETHANE RADIATOR AND CAB MOUNT <b>PBC-10176P</b> OEM X-066-176, K-600,476869C1 	<b>SOPORTE PARA CAMAROTE Y RADIADOR</b> RADIATOR AND CAB MOUNT <b>PBC-10177</b> OEM K-066-177, M500-46230OC2 	<b>SOPORTE PARA CAMAROTE Y RADIADOR POLIURETANO</b> URETHANE RADIATOR AND CAB MOUNT <b>PBC-10177P</b> OEM K-066-177, M500-46230OC2 
SUSPENSIÓN: KENWORTH T-800 INTERNATIONAL / NAVISTAR	SUSPENSIÓN: KENWORTH T-800 INTERNATIONAL / NAVISTAR	SUSPENSIÓN: KENWORTH T-800 INTERNATIONAL / NAVISTAR
<b>ESPECIFICACIONES</b> A= 2 5/16" DE 1= 1 13/16" DE 2= 3" DI= 5/8" HD= 80	<b>ESPECIFICACIONES</b> A= 2 3/16" DE 1= 1 1/2" DE 2= 2 1/2" DI= 5/8"	<b>ESPECIFICACIONES</b> A= 2 3/16" DE 1= 1 1/2" DE 2= 2 1/2" DI= 5/8" HD= 80

<b>BUJE PARA TENSOR DE RADIADOR</b> RADIATOR TIE ROD BUSHING <b>PBC-1030</b> OEM K-264-84 	<b>BUJE PARA TENSOR DE RADIADOR CON METAL</b> RADIATOR TIE ROD BUSHING <b>PBC-1031</b> OEM K-264-84 	<b>BUJE PARA TENSOR DE RADIADOR POLIURETANO</b> URETHANE RADIATOR ROD BUSHING <b>PBC-1031P</b> OEM K-264-84 
SUSPENSIÓN: KENWORTH	SUSPENSIÓN: KENWORTH	SUSPENSIÓN: KENWORTH
<b>ESPECIFICACIONES</b> A= 7/8" DE= 1 21/32" DI= 5/8"	<b>ESPECIFICACIONES</b> A= 7/8" DE= 1 21/32" DI= 5/8" CON METAL INTERIOR / UPPER AND LOWER METAL	<b>ESPECIFICACIONES</b> A= 7/8" DE= 1 21/32" DI= 5/8" HD= 80

<b>SOPORTE PARA RADIADOR Y CABINA</b> RADIATOR AND CAB MOUNT <b>PBC-1036</b> OEM K-066-336, M602 	<b>SOPORTE PARA RADIADOR Y CABINA POLIURETANO</b> URETHANE RADIATOR AND CAB MOUNT <b>PBC-1036P</b> OEM K-066-336, M602 	<b>BUJE PARA BISAGRA</b> HOOD HINGE BUSHING <b>PBC-1039</b> OEM K-066-B-218 M300 
SUSPENSIÓN: KENWORTH T-800, DINA INTERNATIONAL / NAVISTAR	SUSPENSIÓN: KENWORTH T-800, DINA INTERNATIONAL / NAVISTAR	SUSPENSIÓN: KENWORTH W-900, T-800
<b>ESPECIFICACIONES</b> A= 2" DI= 5/8" DE 1= 1 27/32" DE 2= 3"	<b>ESPECIFICACIONES</b> A= 2" DI= 5/8" DE 1= 1 27/32" DE 2= 3" HD= 80	<b>ESPECIFICACIONES</b> A= 1 1/4" DI= 1/2" DE 1= 1 1/8" DE 2= 1 5/8"

<b>BUJE PARA BISAGRA POLIURETANO</b> URETHANE HOOD HINGE BUSHING <b>PBC-1039P</b> OEM K-066-B-218 M300 	<b>BUJE PARA BISAGRA</b> HOOD HINGE BUSHING <b>PBC-1040</b> OEM 	<b>CUBRE POLVO PARA PALANCA DE VELOCIDADES</b> DUST COVER <b>PBC-1061</b> OEM K-042-0045 
SUSPENSIÓN: KENWORTH W-900, T-800	SUSPENSIÓN: DINA	SUSPENSIÓN: KENWORTH W-900
<b>ESPECIFICACIONES</b> A= 1 1/4" DI= 1/2" DE 1= 1 1/8" DE 2= 1 5/8" HD= 80	<b>ESPECIFICACIONES</b> A= 1 1/2" DI= 5/8" DE 1= 1 5/16" DE 2= 2 1/16"	<b>ESPECIFICACIONES</b>

<b>CUBRE POLVO PARA PALANCA DE VELOCIDADES</b> DUST COVER		<b>BUJE AMORTIGUADOR PARA CABINA, CAMAROTE Y RADIADOR</b> CAB AND RADIATOR MOUNT		<b>BUJE AMORTIGUADOR PARA CABINA, CAMAROTE Y RADIADOR POLIURETANO</b> URETHANE CAB AND RADIATOR MOUNT	
<b>PBC-1063</b>		<b>PBC-1069</b>		<b>PBC-1069P</b>	
					
OEM		OEM K-066-251, M601-70-NR		OEM K-066-251, M601-70-NR	
SUSPENSIÓN:	KENWORTH T-800	SUSPENSIÓN:	KENWORTH W-900	SUSPENSIÓN:	KENWORTH W-900
ESPECIFICACIONES		ESPECIFICACIONES		ESPECIFICACIONES	
		A= 1 1/4" DI= 5/8" DE 1= 1 13/16" DE 2= 2 15/16"		A= 1 1/4" DI= 5/8" DE 1= 1 13/16" DE 2= 2 15/16" HD= 80	

<b>BUJE PARA BISAGRA DE COFRE</b> HOOD HINGE BUSHING		<b>BUJE PARA BISAGRA DE COFRE POLIURETANO</b> URETHANE HOOD HINGE BUSHING		<b>BUJE PARA BISAGRA DE COFRE</b> HOOD HINGE BUSHING	
<b>PBC-503359C1</b>		<b>PBC-503359C1P</b>		<b>PBC-17002</b>	
					
OEM 503359C1		OEM 503359C1		OEM LORJ 17002	
SUSPENSIÓN:	INTERNATIONAL / NAVISTAR	SUSPENSIÓN:	INTERNATIONAL / NAVISTAR	SUSPENSIÓN:	FREIGHTLINER
ESPECIFICACIONES		ESPECIFICACIONES		ESPECIFICACIONES	
DE= 1 7/16" DI= 5/8" L= 2 15/16"		DE= 1 7/16" DI= 5/8" L= 2 15/16"		DE= 1 3/8" DI= 1/2" L= 2 3/16"	

<b>BUJE PARA BISAGRA DE COFRE POLIURETANO</b> URETHANE HOOD HINGE BUSHING		<b>SOPORTE PARA CABINA FREIGHTLINER</b> CAB MOUNT		<b>SOPORTE PARA CABINA FREIGHTLINER POLIURETANO</b> URETHANE CAB MOUNT	
<b>PBC-17002P</b>		<b>PBC-1769</b>		<b>PBC-1769P</b>	
					
OEM LORJ 17002		OEM LORD BJ-17699		OEM LORD BJ-17699	
SUSPENSIÓN:	FREIGHTLINER	SUSPENSIÓN:	FREIGHTLINER COLUMBIA	SUSPENSIÓN:	FREIGHTLINER COLUMBIA
ESPECIFICACIONES		ESPECIFICACIONES		ESPECIFICACIONES	
DE= 1 3/8" DI= 1/2" L= 2 3/16" HD= 80		DE= 3 3/4" DI= 5/8" L= 3 1/8"		DE= 3 3/4" DI= 5/8" L= 3 1/8" HD= 80	

<b>SOPORTE PARA RADIADOR</b> RADIATOR MOUNT		<b>BUJE UNIVERSAL DE VOLTEO PARA CABINA</b> CAB HINGE BUSHING		<b>BUJE ANTIVIBRADOR</b> CAB MOUNT	
<b>PBC-503401C1</b>		<b>PBC-987395R2S</b>		<b>PBC-1070</b>	
					
OEM 503401C1		OEM 987395R2S		OEM	
SUSPENSIÓN:	INTERNATIONAL / NAVISTAR	SUSPENSIÓN:	INTERNATIONAL / NAVISTAR	SUSPENSIÓN:	SOPORTE UNIVERSAL
ESPECIFICACIONES		ESPECIFICACIONES		ESPECIFICACIONES	
A= 1 1/2" DE= 1 15/16" DI= 1/2"		A= 1 1/4" DE= 1 1/2" DI= 3/4"		A= 1" DE= 3" DI= 5/8"	

<b>SOPORTE PARA CABINA</b> CAB MOUNT		<b>SOPORTE PARA CABINA</b> CAB MOUNT		<b>SOPORTE UNIVERSAL</b> CAB MOUNT	
<b>PBC-1071</b>		<b>PBC-1072</b>		<b>PBC-1073</b>	
					
SUSPENSIÓN: SOPORTE UNIVERSAL		SUSPENSIÓN: SOPORTE UNIVERSAL		SUSPENSIÓN: SOPORTE UNIVERSAL	
ESPECIFICACIONES A= 1 13/16" DE= 3 13/16" DI= 3/4"		ESPECIFICACIONES A= 1" DE= 2 7/16" DI= 11/16"		ESPECIFICACIONES A= 5/8" DE= 2 7/8" DI= 9/16"	

<b>SOPORTE UNIVERSAL</b> CAB MOUNT		<b>BUJE PARA PALANCA DE VELOCIDADES</b> TRANSMISSION SHIFTER RUBBER BUSHING		<b>KIT BUJE PARA PALANCA DE VELOCIDADES</b> TRANSMISSION SHIFTER RUBBER BUSHING KIT	
<b>PBC-1074</b>		<b>PBC-63274</b>		<b>PBC-63274K</b>	
					
SUSPENSIÓN: SOPORTE UNIVERSAL		SUSPENSIÓN: KENWORTH		SUSPENSIÓN: KENWORTH	
ESPECIFICACIONES A= 1 5/8" DE= 2 15/16" DI= 3/4"		ESPECIFICACIONES A= 2 13/32" DE 1= 1 1/2" DE 2= 1 13/16" DI= 13/16"		ESPECIFICACIONES A= 2 13/32" DE 1= 1 1/2" DE 2= 1 13/16" DI= 13/16"	

<b>BUJE PARA PALANCA DE VELOCIDADES POLIURETANO</b> TRANSMISSION SHIFTER URETHANE BUSHING		<b>KIT BUJE PARA PALANCA DE VELOCIDADES POLIURETANO</b> TRANSMISSION SHIFTER URETHANE BUSHING KIT		<b>SOPORTE PARA CABINA</b> RUBBER CAB MOUNT	
<b>PBC-63274P</b>		<b>PBC-63274KP</b>		<b>PBC-03510</b>	
					
SUSPENSIÓN: KENWORTH		SUSPENSIÓN: KENWORTH		SUSPENSIÓN: PETERBILT	
ESPECIFICACIONES A= 2 13/32" DE 1= 1 1/2" DE 2= 1 13/16" DI= 13/16" HD= 85		ESPECIFICACIONES A= 2 13/32" DE 1= 1 1/2" DE 2= 1 13/16" DI= 13/16" HD= 85		ESPECIFICACIONES ALTO= 1 31/32" ANCHO= 2 3/8" LARGO= 3 1/8"	

<b>SOPORTE PARA CABINA POLIURETANO</b> URETHANE CAB MOUNT		<b>SOPORTE PARA CABINA POLIURETANO</b> URETHANE CAB MOUNT		<b>SOPORTE PARA RADIADOR FREIGHTLINER</b> RADIATOR MOUNT	
<b>PBC-03510P</b>		<b>PBC-20QL2101P</b>		<b>PBC-516070</b>	
					
SUSPENSIÓN: PETERBILT		SUSPENSIÓN: MACK		SUSPENSIÓN: FREIGHTLINER	
ESPECIFICACIONES ALTO= 1 31/32" ANCHO= 2 3/8" LARGO= 3 1/8" HD= 80		ESPECIFICACIONES A= 1 59/64" DE= 2 5/8" DI= 5/8" HD= 80		ESPECIFICACIONES A= 1 3/4" DE 1= 1 1/2" DE 2= 3" DI= 11/16"	

<b>SOPORTE PARA RADIADOR FREIGHTLINER POLIURETANO</b> URETHANE RADIATOR MOUNT		<b>SOPORTE INFERIOR PARA CABINA</b> LOWER CAB MOUNT		<b>SOPORTE INFERIOR PARA CABINA POLIURETANO</b> URETHANE LOWER CAB MOUNT	
<b>PBC-516070P</b> OEM 051-6070-000		<b>PBC-681890</b> OEM L 6818900001, LORSSB3310017		<b>PBC-681890P</b> OEM L 6818900001, LORSSB3310017	
					
SUSPENSIÓN:	FREIGHTLINER	SUSPENSIÓN:	FREIGHTLINER	SUSPENSIÓN:	FREIGHTLINER
<b>ESPECIFICACIONES</b> A= 1 3/4" DE= 1 1/2" DE 2= 3" DI= 11/16" HD= 80		<b>ESPECIFICACIONES</b> A= 2 9/16" DE= 3 13/16" DI= 3/4"		<b>ESPECIFICACIONES</b> A= 2 9/16" DE= 3 13/16" DI= 3/4" HD= 80	

<b>SOPORTE SUPERIOR PARA CABINA</b> UPPER CAB MOUNT		<b>SOPORTE SUPERIOR PARA CABINA POLIURETANO</b> URETHANE UPPER CAB MOUNT		<b>SOPORTE PARA CABINA POLIURETANO</b> URETHANE CAB MOUNT	
<b>PBC-681891</b> OEM 6818910001, LORSSB3310017		<b>PBC-681891P</b> OEM 6818910001 LORSSB3310017		<b>PBC-8257P</b> OEM 8257	
					
SUSPENSIÓN:	FREIGHTLINER	SUSPENSIÓN:	FREIGHTLINER	SUSPENSIÓN:	PETERBILL
<b>ESPECIFICACIONES</b> A= 1 5/16" DE= 3 3/4" DI= 1 3/16"		<b>ESPECIFICACIONES</b> A= 1 5/16" DE= 3 3/4" DI= 1 3/16" HD=80		<b>ESPECIFICACIONES</b> DE = 3" DI= 5/8" ALTO=5/8" HD = 80	

<b>SOPORTE TRASERO PARA CABINA</b> REAR MOTOR MOUNT		<b>SOPORTE TRASERO PARA CABINA POLIURETANO</b> URETHANE REAR MOTOR MOUNT		<b>SOPORTE PARA RADIADOR</b> RADIATOR MOUNT	
<b>PBC-899397</b> OEM 899397		<b>PBC-899397P</b> OEM 899397		<b>PBC-28847</b> OEM BCD-28847-1	
					
SUSPENSIÓN:	VOLKSWAGEN	SUSPENSIÓN:	VOLKSWAGEN	SUSPENSIÓN:	FREIGHTLINER COLUMBIA
<b>ESPECIFICACIONES</b> DE= 3 9/32" DI= 1 41/64" DI2= 3/4" L= 1 7/64"		<b>ESPECIFICACIONES</b> DE= 3 9/32" DI= 1 41/64" DI2= 3/4" L= 1 7/64" HD=80		<b>ESPECIFICACIONES</b> LARGO=4 ESPESOR=1 1/4" ANCHO=3 15/16 TORNILLO 1/2 13 UNC X 2 (2) Y 1 1/4 (1)	

<b>SOPORTE PARA RADIADOR POLIURETANO</b> URETHANE RADIATOR MOUNT	
<b>PBC-28847P</b> OEM BCD-28847-1	
	
SUSPENSIÓN:	FREIGHTLINER COLUMBIA
<b>ESPECIFICACIONES</b> LARGO=4 ESPESOR=1 1/4" ANCHO=3 15/16 TORNILLO 1/2 13 UNC X 2 (2) Y 1 1/4 (1) HD= 80	

**PARBO** M.R.  
PARTES PARA SUSPENSION  
FOR A SMOOTH RIDE®

**PARBO** M.R.

PARTES PARA SUSPENSION

*PARA UN MANEJO SUAVE®*



# SOPORTES PARA MOTOR MOTOR MOUNTS

**PARBO**<sup>M.R.</sup>  
PARTES PARA SUSPENSION  
*PARA UN MANEJO SUAVE*

<b>SOPORTE DELANTERO PARA MOTOR</b> FRONT MOTOR MOUNT	<b>SOPORTE DELANTERO PARA MOTOR POLIURETANO</b> URETHANE FRONT MOTOR MOUNT	<b>SOPORTE TRASERO PARA MOTOR</b> REAR MOTOR MOUNT
<b>PBM-200-08</b> OEM 479237C1	<b>PBM-200-08P</b> OEM 479237C1	<b>PBM-200-09</b> OEM 470031C2
		
SUSPENSIÓN: FAMSA Y DINA INTERNATIONAL/NAVISTAR	SUSPENSIÓN: FAMSA Y DINA INTERNATIONAL/NAVISTAR	SUSPENSIÓN: FAMSA Y DINA INTERNATIONAL/NAVISTAR
<b>ESPECIFICACIONES</b> A= 2 1/2" DI= 5/8" DE 1= 1 9/16" DE 2= 2 11/16" DE 3= 3 1/8"	<b>ESPECIFICACIONES</b> A= 2 1/2" DI= 5/8" DE 1= 1 9/16" DE 2= 2 11/16" DE 3= 3 1/8" HD=80	<b>ESPECIFICACIONES</b> A= 2 5/16" DI= 5/8" DE 1= 1 15/32" DE 2= 2 15/16" DE 3= 2 7/8"

<b>SOPORTE TRASERO PARA MOTOR POLIURETANO</b> URETHANE REAR MOTOR MOUNT	<b>GUÍA PARA BAYONETA DE ACEITE DE MOTOR</b> OIL ENGINE PLUG	<b>SOPORTE PARA MOTOR POLIURETANO</b> URETHANE MOTOR MOUNT
<b>PBM-200-09P</b> OEM 470031C2	<b>PBM-200-10</b> OEM	<b>PBM-10197P</b> OEM 05-10197
		
SUSPENSIÓN: FAMSA Y DINA INTERNATIONAL/NAVISTAR	SUSPENSIÓN: CUMMINS	SUSPENSIÓN:
<b>ESPECIFICACIONES</b> A= 2 5/16" DI= 5/8" DE 1= 1 15/32" DE 2= 2 15/16" DE 3= 2 7/8" HD= 80	<b>ESPECIFICACIONES</b> A= 3/4" DE 1= 1" DE 2= 1 1/4" DI= 3/8"	<b>ESPECIFICACIONES</b> A= 2 13/32" DI= 13/16" DE 1= 1 5/8" DE 2= 2 11/16" HD=80

<b>SOPORTE PARA MOTOR POLIURETANO</b> URETHANE MOTOR MOUNT	<b>SOPORTE PARA MOTOR</b> MOTOR MOUNT	<b>SOPORTE DELANTERO PARA MOTOR POLIURETANO</b> URETHANE FRONT MOTOR MOUNT
<b>PBM-20QL312M2P</b> OEM 20QL312M2	<b>PBM-200-20QL252</b> OEM 20QL252P8	<b>PBM-200-20QL258P</b> OEM 20QL258
		
SUSPENSIÓN: MACK	SUSPENSIÓN: MACK	SUSPENSIÓN: MACK
<b>ESPECIFICACIONES</b> DE = 2 5/8" DI = 5/8" ALTO= 1 1/8" HD = 80	<b>ESPECIFICACIONES</b> A= 2 1/2" DI= 3/4" DE 1= 2 3/16" DE 2= 2 5/8"	<b>ESPECIFICACIONES</b> A= 2 29/32" DI= 29/32" DE= 3 1/2" HD= 80

<b>SOPORTE DELANTERO PARA MOTOR POLIURETANO</b> URETHANE FRONT MOTOR MOUNT	<b>SOPORTE DELANTERO PARA MOTOR</b> FRONT MOTOR MOUNT	<b>SOPORTE DELANTERO PARA MOTOR POLIURETANO</b> URETHANE FRONT MOTOR MOUNT
<b>PBM-200-20QL1166P</b> OEM 20QL1166	<b>PBM-200-20QL324M</b> OEM 20QL324M	<b>PBM-200-20QL324MP</b> OEM 20QL324M
		
SUSPENSIÓN: MACK	SUSPENSIÓN: MACK	SUSPENSIÓN: MACK
<b>ESPECIFICACIONES</b> ANCHO= 1 1/4" ESPESOR= 5/8" LARGO= 5 27/32 HD= 80	<b>ESPECIFICACIONES</b> A= 1 7/8" DI= 7/8" DE 1= 2 1/2" DE 2= 3 5/8"	<b>ESPECIFICACIONES</b> A= 1 7/8" DI= 7/8" DE 1= 2 1/2" DE 2= 3 5/8" HD= 80

<p><b>SOPORTE PARA MOTOR</b> MOTOR MOUNT</p> <p><b>PBM-200-29</b></p> <p>OEM K174-555</p> 	<p><b>SOPORTE PARA MOTOR POLIURETANO</b> URETHANE MOTOR MOUNT</p> <p><b>PBM-200-29P</b></p> <p>OEM K174-555</p> 	<p><b>SOPORTE PARA MOTOR POLIURETANO</b> URETHANE MOTOR MOUNT</p> <p><b>PBM-200-29MP</b></p> <p>OEM K174-555</p> 						
<p>SUSPENSIÓN: KENWORTH W-900</p>	<p>SUSPENSIÓN: KENWORTH W-900</p>	<p>SUSPENSIÓN: KENWORTH W-900</p>						
<p><b>ESPECIFICACIONES</b> ANCHO= 2" ESPESOR= 1/2" LARGO= 4 1/2" CON METAL INTERIOR Y EXTERIOR / INNER AND OUTER METAL</p>			<p><b>ESPECIFICACIONES</b> ANCHO= 2" ESPESOR= 1/2" LARGO= 4 1/2" HD= 80</p>			<p><b>ESPECIFICACIONES</b> ANCHO= 2" ESPESOR= 1/2" LARGO= 4 1/2" HD= 80 CON METAL INTERIOR Y EXTERIOR / INNER AND OUTER METAL</p>		
<p><b>SOPORTE DELANTERO PARA MOTOR</b> FRONT MOTOR MOUNT</p> <p><b>PBM-200-30</b></p> <p>OEM 550053</p> 	<p><b>SOPORTE TRASERO PARA MOTOR POLIURETANO</b> URETHANE REAR MOTOR MOUNT</p> <p><b>PBM-200-31P</b></p> <p>OEM</p> 	<p><b>SOPORTE PARA MOTOR</b> MOTOR MOUNT</p> <p><b>PBM-200-32</b></p> <p>OEM 2235153</p> 						
<p>SUSPENSIÓN: MOTOR PERKINS</p>	<p>SUSPENSIÓN: MOTOR PERKINS (DODGE)</p>	<p>SUSPENSIÓN: MOTOR PERKINS</p>						
<p><b>ESPECIFICACIONES</b> L= 4 5/16" ANCHO= 2 3/16" A= 1 21/32"</p>			<p><b>ESPECIFICACIONES</b> L= 5 5/16" ANCHO= 1 5/8" A= 1 1/8" HD= 80</p>			<p><b>ESPECIFICACIONES</b> ANCHO= 3 5/8" L= 4 3/8"</p>		
<p><b>SOPORTE DELANTERO PARA MOTOR POLIURETANO</b> URETHANE FRONT MOTOR MOUNT</p> <p><b>PBM-200-3208P</b></p> <p>OEM 12005-3208</p> 	<p><b>SOPORTE PARA MOTOR, CASETA Y LITERA</b> MOTOR MOUNT</p> <p><b>PBM-3928900</b></p> <p>OEM</p> 	<p><b>SOPORTE PARA MOTOR, CASETA Y LITERA POLIURETANO</b> URETHANE MOTOR MOUNT</p> <p><b>PBM-3928900P</b></p> <p>OEM</p> 						
<p>SUSPENSIÓN: VOLVO</p>	<p>SUSPENSIÓN: CUMMINS</p>	<p>SUSPENSIÓN: CUMMINS</p>						
<p><b>ESPECIFICACIONES</b> A= 1 3/64" DE= 2 51/64" DI= 21/32" HD= 80</p>			<p><b>ESPECIFICACIONES</b> DE= 2 3/8" DI= 3/4" L= 3 3/4"</p>			<p><b>ESPECIFICACIONES</b> DE= 2 3/8" DI= 3/4" L= 3 3/4" HD= 80</p>		
<p><b>SOPORTE PARA MOTOR, CASETA Y LITERA</b> MOTOR MOUNT</p> <p><b>PBM-200-52</b></p> <p>OEM 753997C93</p> 	<p><b>SOPORTE PARA MOTOR, CASETA Y LITERA POLIURETANO</b> URETHANE MOTOR MOUNT</p> <p><b>PBM-200-52P</b></p> <p>OEM 753997C93</p> 	<p><b>SOPORTE DELANTERO PARA MOTOR</b> FRONT MOTOR MOUNT</p> <p><b>PBM-200-56</b></p> <p>OEM 20QL1175</p> 						
<p>SUSPENSIÓN: KENWORTH, DINA</p>	<p>SUSPENSIÓN: KENWORTH, DINA</p>	<p>SUSPENSIÓN: MACK</p>						
<p><b>ESPECIFICACIONES</b> A= 2 1/4" DI= 5/8" DE1= 2" DE2= 2 15/16"</p>			<p><b>ESPECIFICACIONES</b> A= 2 1/4" DI= 5/8" DE1= 2" DE2= 2 15/16" HD= 80</p>			<p><b>ESPECIFICACIONES</b> A= 1 1/2" DI= 3/4" DE1= 2" DE2= 3 1/4"</p>		

<b>SOPORTE DELANTERO PARA MOTOR POLIURETANO</b> URETHANE FRONT MOTOR MOUNT		<b>SOPORTE TRASERO PARA MOTOR</b> REAR MOTOR MOUNT		<b>SOPORTE TRASERO PARA MOTOR POLIURETANO</b> URETHANE REAR MOTOR MOUNT	
<b>PBM-200-56P</b>		<b>PBM-200-57</b>		<b>PBM-200-59P</b>	
OEM 20QL175		OEM 20QL258		OEM	
					
SUSPENSIÓN:	MACK	SUSPENSIÓN:	MACK	SUSPENSIÓN:	MACK
ESPECIFICACIONES		ESPECIFICACIONES		ESPECIFICACIONES	
A= 1 1/2" DI= 3/4" DE1= 2" DE2= 3 1/4" HD= 80		A=3 1/8" DI= 7/8" DE= 3 7/16"		DE= 3 1/2" DI= 1 13/32" ESPESOR= 1" HD= 80	

<b>SOPORTE PARA MOTOR</b> MOTOR MOUNT		<b>SOPORTE PARA MOTOR POLIURETANO</b> URETHANE MOTOR MOUNT		<b>SOPORTE DELANTERO PARA MOTOR</b> FRONT MOTOR MOUNT	
<b>PBM-200-65017</b>		<b>PBM-200-65017P</b>		<b>PBM-200-80</b>	
OEM QLORCBA2465017		OEM QLORCBA2465017		OEM KO66-404 Y KO66-2423	
					
SUSPENSIÓN:	FREIGHTLINER	SUSPENSIÓN:	FREIGHTLINER	SUSPENSIÓN:	KENWORTH
ESPECIFICACIONES		ESPECIFICACIONES		ESPECIFICACIONES	
A= 2 1/8" DI= 5/8" DE1= 1 15/32" DE2= 2 5/16		A= 2 1/8" DI= 5/8" DE1= 1 15/32" DE2= 2 5/16 HD=80		A= 2 3/8" DE= 3 1/4" DI= 13/16"	

<b>SOPORTE DELANTERO PARA MOTOR</b> FRONT MOTOR MOUNT		<b>SOPORTE DELANTERO PARA MOTOR</b> FRONT MOTOR MOUNT		<b>SOPORTE DELANTERO PARA MOTOR POLIURETANO</b> URETHANE FRONT MOTOR MOUNT	
<b>PBM-200-80A</b>		<b>PBM-200-80B</b>		<b>PBM-200-80P</b>	
OEM		OEM		OEM KO66-404 Y KO66-2423	
					
SUSPENSIÓN:	KENWORTH	SUSPENSIÓN:	KENWORTH	SUSPENSIÓN:	KENWORTH
ESPECIFICACIONES		ESPECIFICACIONES		ESPECIFICACIONES	
A= 2 1/8" DI= 13/16" DE= 3 1/32"		A= 17/32" DI= 13/16" DE= 3 1/32"		A= 2 3/8" DE= 3 1/4" DI= 13/16" HD= 80	

<b>SOPORTE DELANTERO PARA MOTOR POLIURETANO</b> URETHANE FRONT MOTOR MOUNT		<b>SOPORTE DELANTERO PARA MOTOR POLIURETANO</b> URETHANE FRONT MOTOR MOUNT		<b>SOPORTE PARA MOTOR</b> MOTOR MOUNT	
<b>PBM-200-80AP</b>		<b>PBM-200-80BP</b>		<b>PBM-200-82</b>	
OEM		OEM		OEM K-O66-282, K-O66-320, M506	
					
SUSPENSIÓN:	KENWORTH	SUSPENSIÓN:	KENWORTH	SUSPENSIÓN:	KENWORTH T-600, T-800
ESPECIFICACIONES		ESPECIFICACIONES		ESPECIFICACIONES	
A= 2 1/8" DI= 13/16" DE= 3 1/32" HD= 80		A= 17/32" DI= 13/16" DE= 3 1/32" HD= 80		ANCHO= 2" DI= 5/8" L= 5 5/8"	

<p><b>SOPORTE PARA MOTOR POLIURETANO</b> URETHANE MOTOR MOUNT</p> <p><b>PBM-200-82P</b></p> <p>OEM K-066-282, K-066-320, M506</p> 	<p><b>SOPORTE TRASERO PARA MOTOR</b> REAR MOTOR MOUNT</p> <p><b>PBM-200-83</b></p> <p>OEM O4-900997</p> 	<p><b>SOPORTE TRASERO PARA MOTOR POLIURETANO</b> URETHANE REAR MOTOR MOUNT</p> <p><b>PBM-200-83P</b></p> <p>OEM O4-900997</p> 
<p>SUSPENSIÓN: KENWORTH T-600, T-800</p> <p><b>ESPECIFICACIONES</b> ANCHO= 2" DI= 5/8" L=5 5/8" HD= 80</p>	<p>SUSPENSIÓN: VOLVO</p> <p><b>ESPECIFICACIONES</b> ANCHO= 3" DI= 5/8" L=6"</p>	<p>SUSPENSIÓN: VOLVO</p> <p><b>ESPECIFICACIONES</b> ANCHO= 3" DI= 5/8" L=6" HD= 80A</p>
<p><b>SOPORTE TRASERO PARA MOTOR</b> REAR MOTOR MOUNT</p> <p><b>PBM-200-84</b></p> <p>OEM</p> 	<p><b>SOPORTE TRASERO PARA MOTOR POLIURETANO</b> URETHANE REAR MOTOR MOUNT</p> <p><b>PBM-200-84P</b></p> <p>OEM</p> 	<p><b>SOPORTE DELANTERO PARA MOTOR POLIURETANO</b> URETHANE FRONT MOTOR MOUNT</p> <p><b>PBM-200-85P</b></p> <p>OEM BCD-2670411, BCD-276511</p> 
<p>SUSPENSIÓN: FREIGHTLINER</p> <p><b>ESPECIFICACIONES</b> A= 3" DI= 21/32" ANCHO= 17/16" L= 5 13/32"</p>	<p>SUSPENSIÓN: FREIGHTLINER</p> <p><b>ESPECIFICACIONES</b> A= 3" DI= 21/32" ANCHO= 17/16" L= 5 13/32" HD=80</p>	<p>SUSPENSIÓN: FREIGHTLINER CENTURY</p> <p><b>ESPECIFICACIONES</b></p>
<p><b>SOPORTE TRASERO PARA MOTOR POLIURETANO</b> URETHANE REAR MOTOR MOUNT</p> <p><b>PBM-49169P</b></p> <p>OEM 3549169CZ</p> 	<p><b>SOPORTE TRASERO PARA MOTOR POLIURETANO</b> URETHANE REAR MOTOR MOUNT</p> <p><b>PBM-200-86P</b></p> <p>OEM BCD-274772, BDC-27330</p> 	<p><b>SOPORTE TRASERO PARA MOTOR</b> REAR MOTOR MOUNT</p> <p><b>PBM-200-91</b></p> <p>OEM 503579C1, DOHZ6068B</p> 
<p>SUSPENSIÓN: INTERNATIONAL</p> <p><b>ESPECIFICACIONES</b> ANCHO= 3 7/18" LARGO= 4 7/8" HD = 80</p>	<p>SUSPENSIÓN: FREIGHTLINER CENTURY</p> <p><b>ESPECIFICACIONES</b> ANCHO= 3" LARGO= 9 7/8" HD= 80 A</p>	<p>SUSPENSIÓN: INTERNATIONAL / NAVISTAR, FREIGHTLINER, FORD, DINA, VOLVO</p> <p><b>ESPECIFICACIONES</b> A= 3" DE= 3" DI= 1 1/2"</p>
<p><b>SOPORTE TRASERO PARA MOTOR POLIURETANO</b> URETHANE REAR MOTOR MOUNT</p> <p><b>PBM-200-91P</b></p> <p>OEM 503579C1, DOHZ6068B</p> 	<p><b>SOPORTE DELANTERO PARA MOTOR Y CAMAROTE</b> FRONT MOTOR MOUNT</p> <p><b>PBM-200-98</b></p> <p>OEM K-066-229, M700</p> 	<p><b>SOPORTE DELANTERO PARA MOTOR Y CAMAROTE POLIURETANO</b> URETHANE FRONT MOTOR MOUNT</p> <p><b>PBM-200-98P</b></p> <p>OEM K-066-229, M700</p> 
<p>SUSPENSIÓN: INTERNATIONAL / NAVISTAR, FREIGHTLINER, FORD, DINA, VOLVO</p> <p><b>ESPECIFICACIONES</b> A= 3" DE= 3" DI= 1 1/2" HD= 80</p>	<p>SUSPENSIÓN: KENWORTH T-800, W-900, DINA 861</p> <p><b>ESPECIFICACIONES</b> A= 2 5/8" DI= 3/4" DE1= 2" DE2= 2 3/8"</p>	<p>SUSPENSIÓN: KENWORTH T-800, W-900, DINA 861</p> <p><b>ESPECIFICACIONES</b> A= 2 5/8" DI= 3/4" DE1= 2" DE2= 2 3/8" HD= 80</p>

<b>SOPORTE TRASERO PARA MOTOR POLIURETANO</b> URETHANE REAR MOTOR MOUNT		<b>SOPORTE DELANTERO PARA MOTOR</b> FRONT MOTOR MOUNT		<b>SOPORTE DELANTERO PARA MOTOR POLIURETANO</b> URETHANE FRONT MOTOR MOUNT	
<b>PBM-11160P</b>		<b>PBM-C8TZ-6038-B</b>		<b>PBM-C8TZ-6038-BP</b>	
OEM A01-11160-000		OEM C8TZ-6038-B		OEM C8TZ-6038-B	
					
SUSPENSIÓN:	FREIGHTLINER	SUSPENSIÓN:	CATERPILLAR 3208	SUSPENSIÓN:	CATERPILLAR 3208
<b>ESPECIFICACIONES</b>		<b>ESPECIFICACIONES</b>		<b>ESPECIFICACIONES</b>	
ANCHO= 2 1/4" ESPESOR= 1 1/2" LARGO= 3" HD= 80		ANCHO= 2 5/16" ESPESOR= 1 7/16" LARGO= 8 1/8"		ANCHO= 2 5/16" ESPESOR= 1 7/16" LARGO= 8 1/8" HD=80	

<b>SOPORTE PARA MOTOR</b> MOTOR MOUNT		<b>SOPORTE PARA MOTOR POLIURETANO</b> URETHANE MOTOR MOUNT		<b>SOPORTE TRASERO PARA MOTOR</b> REAR MOTOR MOUNT	
<b>PBM-C8TZ-6068-B</b>		<b>PBM-C8TZ-6068-BP</b>		<b>PBM-C8TZ-6A061-A</b>	
OEM C8TZ-6068-B		OEM C8TZ-6068-B		OEM-C8TZ-6A061-A	
					
SUSPENSIÓN:	CATERPILLAR 3208	SUSPENSIÓN:	CATERPILLAR 3208	SUSPENSIÓN:	CATERPILLAR 3208
<b>ESPECIFICACIONES</b>		<b>ESPECIFICACIONES</b>		<b>ESPECIFICACIONES</b>	
ANCHO= 3 1/4" ESPESOR= 2 1/4" DI= 3/4" L= 5 1/4"		ANCHO= 3 1/4" ESPESOR= 2 1/4" DI= 3/4" L= 5 1/4" HD=80		ANCHO= 2 7/8" ESPESOR= 1 5/16" DI= 3/4" L= 3 1/8"	

<b>SOPORTE TRASERO PARA MOTOR POLIURETANO</b> URETHANE REAR MOTOR MOUNT		<b>SOPORTE DELANTERO PARA MOTOR POLIURETANO</b> URETHANE FRONT MOTOR MOUNT		<b>SOPORTE DELANTERO PARA MOTOR POLIURETANO</b> URETHANE FRONT MOTOR MOUNT	
<b>PBM-C8TZ-6A061-AP</b>		<b>PBM-200-286235C2P</b>		<b>PBM-200-286236C2P</b>	
OEM-C8TZ-6A061-A		OEM 286235C2		OEM 286236C2	
					
SUSPENSIÓN:	CATERPILLAR 3208	SUSPENSIÓN:	INTERNATIONAL / NAVISTAR	SUSPENSIÓN:	INTERNATIONAL / NAVISTAR
<b>ESPECIFICACIONES</b>		<b>ESPECIFICACIONES</b>		<b>ESPECIFICACIONES</b>	
ANCHO= 2 7/8" ESPESOR= 1 5/16" DI= 3/4" L= 3 1/8" HD= 80		ALTURA= 1 1/2" ANCHO= 1 1/2" L= 5" HD= 80		ALTURA= 1 1/2" ANCHO= 2 1/4" L= 6 3/8" HD= 80	

<b>SOPORTE DELANTERO PARA MOTOR</b> FRONT MOTOR MOUNT		<b>SOPORTE INFERIOR PARA MOTOR</b> LOWER MOTOR MOUNT		<b>SOPORTE SUPERIOR TRASERO PARA MOTOR</b> UPPER REAR MOTOR MOUNT	
<b>PBM-200-1664723C2</b>		<b>PBM-200-1664726C2</b>		<b>PBM-200-1664727C1</b>	
OEM 1664723C2		OEM 1664726C2		OEM 1664727C1	
					
SUSPENSIÓN:	INTERNATIONAL / NAVISTAR, DINA	SUSPENSIÓN:	INTERNATIONAL / NAVISTAR, DINA	SUSPENSIÓN:	INTERNATIONAL / NAVISTAR, DINA
<b>ESPECIFICACIONES</b>		<b>ESPECIFICACIONES</b>		<b>ESPECIFICACIONES</b>	
ALTURA= 2 1/8" ANCHO= 4" DI= 5/8" L= 4 1/8"		A= 5/8" DE= 3" DI= 5/8"		ANCHO= 3 1/8" DI= 5/8" L= 5 1/2" ALTURA= 3 1/2"	

<b>SOPORTE PARA MOTOR</b> MOTOR MOUNT	<b>SOPORTE SUPERIOR DELANTERO PARA MOTOR</b> UPPER FRONT MOTOR MOUNT	<b>SOPORTE TRASERO INFERIOR PARA MOTOR</b> LOWER REAR MOTOR MOUNT
<b>PBM-200-1664729C1</b> OEM 1664729C1	<b>PBM-200-1664730C5</b> OEM 1664730C5	<b>PBM-200-66377</b> OEM K-066-377
		
SUSPENSIÓN: INTERNATIONAL / NAVISTAR, DINA	SUSPENSIÓN: INTERNATIONAL / NAVISTAR, DINA	SUSPENSIÓN: KENWORTH T-600
<b>ESPECIFICACIONES</b> ALTURA= 4 3/4" ANCHO= 3 3/8" DI= 3/4" L= 7"	<b>ESPECIFICACIONES</b> A= 5/8" DE= 3 9/16" DI= 3/4"	<b>ESPECIFICACIONES</b> ANCHO= 3 1/8" L= 7 13/16" ESPESOR= 2 19/32"

<b>SOPORTE TRASERO INFERIOR PARA MOTOR POLIURETANO</b> URETHANE LOWER REAR MOTOR MOUNT	<b>SOPORTE TRASERO SUPERIOR PARA MOTOR</b> UPPER REAR MOTOR MOUNT	<b>SOPORTE TRASERO SUPERIOR PARA MOTOR POLIURETANO</b> URETHANE UPPER REAR MOTOR MOUNT
<b>PBM-200-66377P</b> OEM K-066-377	<b>PBM-200-66421</b> OEM K-066-421	<b>PBM-200-66421P</b> OEM K-066-421
		
SUSPENSIÓN: KENWORTH T-600	SUSPENSIÓN: KENWORTH T-600	SUSPENSIÓN: KENWORTH T-600
<b>ESPECIFICACIONES</b> ANCHO= 3 1/8" L= 7 13/16" ESPESOR= 2 19/32" HD= 80	<b>ESPECIFICACIONES</b> ANCHO= 2 3/4" L= 4 1/4" DI= 25/32"	<b>ESPECIFICACIONES</b> ANCHO= 2 3/4" L= 4 1/4" DI= 25/32" HD= 80

<b>SOPORTE DE MOTOR POLIURETANO</b> URETHANE MOTOR MOUNT	<b>SOPORTE DE MOTOR POLIURETANO</b> URETHANE MOTOR MOUNT	<b>SOPORTE DELANTERO PARA MOTOR</b> FRONT MOTOR MOUNT
<b>PBM-5123P</b> OEM 512-3NS	<b>PBM-5124P</b> OEM 512-5NS	<b>PBM-2407017</b> OEM 3452407017
		
SUSPENSIÓN: BLUE BIRD TC 2000	SUSPENSIÓN: BLUE BIRD TC 2000	SUSPENSIÓN: MERCEDEZ BENZ
<b>ESPECIFICACIONES</b> DE1= 2 7/16" DE2= 3 1/2" DI= 13/16" ANCHO= 3" HD= 80	<b>ESPECIFICACIONES</b> DE1= 2 1/4" DE2= 2 3/4" DI= 11/16" ANCHO= 3" HD= 80	<b>ESPECIFICACIONES</b> DB= M16_15mm A= 4 53/64" L= 5"

<b>SOPORTE DELANTERO PARA MOTOR POLIURETANO</b> URETHANE FRONT MOTOR MOUNT	<b>SOPORTE PARA CABINA</b> CAB MOUNT	<b>SOPORTE PARA CABINA POLIURETANO</b> URETHANE CAB MOUNT
<b>PBM-2407017P</b> OEM 3452407017	<b>PBM-3310017</b> OEM LORS53310017	<b>PBM-3310017P</b> OEM LORS53310017
		
SUSPENSIÓN: MERCEDEZ BENZ	SUSPENSIÓN: FREIGHTLINER	SUSPENSIÓN: FREIGHTLINER
<b>ESPECIFICACIONES</b> DB= M16_15mm A= 4 53/64" L= 5" HD= 80	<b>ESPECIFICACIONES</b> DE1= 3 49/64 DE2= 2 49/64 DI= 51/64 A= 119/64	<b>ESPECIFICACIONES</b> DE1= 3 49/64 DE2= 2 49/64 DI= 51/64 A= 119/64 HD= 80

<b>SOPORTE PARA MOTOR POLIURETANO</b> URETHANE MOTOR MOUNT		<b>SOPORTE PARA TRANSMISIÓN POLIURETANO</b> URETHANE TRANSMISSION MOUNT		<b>SOPORTE PARA TRANSMISIÓN POLIURETANO</b> URETHANE TRANSMISSION MOUNT	
<b>PBM-18263P</b> OEM 518263		<b>PBM-63275P</b> OEM K363-275		<b>PBM-66269P</b> OEM KO66-269	
					
SUSPENSIÓN:	PETERBILT	SUSPENSIÓN:	KENWORTH	SUSPENSIÓN:	KENWORTH
<b>ESPECIFICACIONES</b> DI= 5/6" DE= 2 1/2" LARGO= 2 7/8" HD = 80		<b>ESPECIFICACIONES</b> DI= 1 1/8" DE= 2 1/4" ESPESOR= 3/8" HD = 80		<b>ESPECIFICACIONES</b> DI= 7/8" DE1= 1 1/2" DE2= 2 3/8" ALTO= 1" HD = 80	

**PARBO**<sup>MR</sup>  
PARTES PARA SUSPENSION

*PARA UN MANEJO SUAVE*®



# BUJES PARA QUINTA RUEDA FIFTH WHEEL BUSHINGS

**PARBO**<sup>M.R.</sup>  
PARTES PARA SUSPENSION  
*PARA UN MANEJO SUAVE*

**PARBO** M.R.

PARTES PARA SUSPENSION

*PARA UN MANEJO SUAVE®*

<p><b>PLANCHA PARA QUINTA RUEDA SIMPLEX TIPO NEWAY</b> FIFTH WHEEL PAD</p> <p><b>PBR-51</b></p> <p>OEM 4111009</p> 	<p><b>PLANCHA PARA QUINTA RUEDA SIMPLEX TIPO NEWAY POLIURETANO</b> URETHANE FIFTH WHEEL PAD</p> <p><b>PBR-51P</b></p> <p>OEM 4111009</p> 	<p><b>BUJE PARA QUINTA RUEDA</b> FIFTH WHEEL BUSHING</p> <p><b>PBR-52</b></p> <p>OEM KO66-160, X1604-5</p> 
<p>SUSPENSION: DINA</p> <p><b>ESPECIFICACIONES</b> L= 10 1/4" ANCHO= 3 5/8" ESPESOR= 5/8"</p>	<p>SUSPENSION: DINA</p> <p><b>ESPECIFICACIONES</b> L= 10 1/4" ANCHO= 3 5/8" ESPESOR= 5/8" HD= 80</p>	<p>SUSPENSION: KENWORTH W-900 HOLLAND</p> <p><b>ESPECIFICACIONES</b> DI= 1 1/8" DE= 2 3/4" L= 4 1/4"</p>
<p><b>BUJE PARA QUINTA RUEDA POLIURETANO</b> URETHANE FIFTH WHEEL BUSHING</p> <p><b>PBR-52P</b></p> <p>OEM KO66-160, X1604-5</p> 	<p><b>BUJE PARA QUINTA RUEDA</b> FIFTH WHEEL BUSHING</p> <p><b>PBR-53</b></p> <p>OEM XB-0011-2</p> 	<p><b>BUJE PARA QUINTA RUEDA POLIURETANO</b> URETHANE FIFTH WHEEL BUSHING</p> <p><b>PBR-53P</b></p> <p>OEM XB-0011-2</p> 
<p>SUSPENSION: KENWORTH W-900 HOLLAND</p> <p><b>ESPECIFICACIONES</b> DI= 1 1/8" DE= 2 3/4" L= 4 1/4" HD=80</p>	<p>SUSPENSION: HOLLAND</p> <p><b>ESPECIFICACIONES</b> DI= 1 1/8" L= 4 3/16"</p>	<p>SUSPENSION: HOLLAND</p> <p><b>ESPECIFICACIONES</b> DI= 1 1/8" L= 4 3/16" HD=80</p>
<p><b>BUJE PARA QUINTA RUEDA</b> FIFTH WHEEL BUSHING</p> <p><b>PBR-54</b></p> <p>OEM</p> 	<p><b>BUJE PARA QUINTA RUEDA</b> FIFTH WHEEL BUSHING</p> <p><b>PBR-55</b></p> <p>OEM BSH-150</p> 	<p><b>BUJE PARA QUINTA RUEDA POLIURETANO</b> URETHANE FIFTH WHEEL BUSHING</p> <p><b>PBR-55P</b></p> <p>OEM BSH-150</p> 
<p>SUSPENSION: HOLLAND</p> <p><b>ESPECIFICACIONES</b> DE= 2 1/8" DI= 1" L= 4 1/4"</p>	<p>SUSPENSION: FONTAINE</p> <p><b>ESPECIFICACIONES</b> DE= 4" DI= 1 1/4" L= 2 1/4"</p>	<p>SUSPENSION: FONTAINE</p> <p><b>ESPECIFICACIONES</b> DE= 4" DI= 1 1/4" L= 2 1/4" HD= 80</p>
<p><b>BUJE PARA QUINTA RUEDA POLIURETANO</b> URETHANE FIFTH WHEEL BUSHING</p> <p><b>PBR-56P</b></p> <p>OEM KO66-160, X1604-5</p> 	<p><b>BUJE PARA QUINTA RUEDA</b> FIFTH WHEEL BUSHING</p> <p><b>PBR-57</b></p> <p>OEM SK 2905-95</p> 	<p><b>BUJE PARA QUINTA RUEDA POLIURETANO</b> URETHANE FIFTH WHEEL BUSHING</p> <p><b>PBR-57P</b></p> <p>OEM SK 2905-95</p> 
<p>SUSPENSION:</p> <p><b>ESPECIFICACIONES</b> DE= 2 13/16" DI= 1 1/8" L= 4 1/4" HD= 80</p>	<p>SUSPENSION: KENWORTH / JOST</p> <p><b>ESPECIFICACIONES</b> DE= 2 3/4" DI= 2" L= 4"</p>	<p>SUSPENSION: KENWORTH / JOST</p> <p><b>ESPECIFICACIONES</b> DE= 2 3/4" DI= 2" L= 4" HD= 80</p>

<b>BUJE PARA QUINTA RUEDA</b> FIFTH WHEEL BUSHING		<b>BUJE PARA QUINTA RUEDA POLIURETANO</b> URETHANE FIFTH WHEEL BUSHING		<b>BUJE PARA QUINTA RUEDA</b> FIFTH WHEEL BUSHING	
<b>PBR-58</b> OEM XB 10605		<b>PBR-58P</b> OEM XB 10605		<b>PBR-59</b> OEM BSH-109-L	
					
SUSPENSIÓN:	HOLLAND	SUSPENSIÓN:	HOLLAND	SUSPENSIÓN:	FONTAINE
<b>ESPECIFICACIONES</b> DE= 2 33/64" DE= 3 59/64" DI= 1 3/16" L= 2 1/64"		<b>ESPECIFICACIONES</b> DE= 2 33/64" DE= 3 59/64" DI= 1 3/16" L= 2 1/64" HD= 80		<b>ESPECIFICACIONES</b> DE= 3 3/16" DI= 1 1/4" L= 2 11/16" L2= 2 5/16"	

<b>BUJE PARA QUINTA RUEDA POLIURETANO</b> URETHANE FIFTH WHEEL BUSHING		<b>BUJE PARA QUINTA RUEDA</b> FIFTH WHEEL BUSHING		<b>BUJE PARA QUINTA RUEDA POLIURETANO</b> URETHANE FIFTH WHEEL BUSHING	
<b>PBR-59P</b> OEM BSH-109-L		<b>PBR-60</b> OEM XB-0012-2		<b>PBR-60P</b> OEM XB-0012-2	
					
SUSPENSIÓN:	FONTAINE	SUSPENSIÓN:	HOLLAND	SUSPENSIÓN:	HOLLAND
<b>ESPECIFICACIONES</b> DE= 3 3/16" DI= 1 1/4" L= 2 11/16" L2= 2 5/16" HD= 80		<b>ESPECIFICACIONES</b> DI= 1 1/2" L= 4 1/8"		<b>ESPECIFICACIONES</b> DI= 1 1/2" L= 4 1/8" HD= 80	

<b>BUJE PARA QUINTA RUEDA POLIURETANO</b> URETHANE SIMPLEX FIFTH WHEEL BUSHING	
<b>PBR-61P</b> OEM ATP-0328-03/4100328	
	
SUSPENSIÓN:	SIMPLEX
<b>ESPECIFICACIONES</b> DE= 27/32" DI= 4 1/2" LARGO = 4" HD= 80	

# BUJES PARA SUSPENSIÓN DE TRÁILER

## TRAILER BUSHINGS

**PARBO**<sup>M.R.</sup>  
PARTES PARA SUSPENSIÓN  
*PARA UN MANEJO SUAVE*

**PARBO** M.R.

PARTES PARA SUSPENSION

*PARA UN MANEJO SUAVE®*

<p><b>BUJE CENTRAL PARA BALANCÍN</b> EQUALIZER BUSHING</p> <p><b>PBJ-116</b></p> <p>OEM 3-12-32</p> 	<p><b>BUJE CENTRAL PARA BALANCÍN POLIURETANO</b> URETHANE EQUALIZER BUSHING</p> <p><b>PBJ-116P</b></p> <p>OEM 3-12-32</p> 	<p><b>BUJE CENTRAL PARA BALANCÍN</b> EQUALIZER BUSHING</p> <p><b>PBJ-128</b></p> <p>OEM 7010-00</p> 
<p>SUSPENSIÓN: TRAILMOBILE</p> <p>ESPECIFICACIONES DB= 3/4" DE= 3 5/16" L= 4 3/8"</p>	<p>SUSPENSIÓN: TRAILMOBILE</p> <p>ESPECIFICACIONES DB= 3/4" DE= 3 5/16" L= 4 3/8" HD= 80</p>	<p>SUSPENSIÓN: HUTCHENS H7600, H7700. CH7700. CH7800, SUDISA</p> <p>ESPECIFICACIONES DB= 3/4" DE= 3 1/4" L= 3 7/8"</p>
<p><b>BUJE CENTRAL PARA BALANCÍN POLIURETANO</b> URETHANE EQUALIZER BUSHING</p> <p><b>PBJ-128P</b></p> <p>OEM 7010-00</p> 	<p><b>BUJE CENTRAL PARA SUSPENSIÓN</b> BEAM CENTER BUSHING</p> <p><b>PBJ-4478</b></p> <p>OEM 90008149, 90008148</p> 	<p><b>BUJE CENTRAL PARA SUSPENSIÓN POLIURETANO</b> URETHANE BEAM CENTER BUSHING</p> <p><b>PBJ-4478P</b></p> <p>OEM 90008149, 90008148</p> 
<p>SUSPENSIÓN: HUTCHENS H7600, H7700. CH7700. CH7800, SUDISA</p> <p>ESPECIFICACIONES DB= 3/4" DE= 3 1/4" L= 3 7/8" HD= 80</p>	<p>SUSPENSIÓN: NEWAY AR-90, RL 196 SUSPENSIÓN DE AIRE</p> <p>ESPECIFICACIONES DE= 2 3/4" DI= 1 1/8" L= 5"</p>	<p>SUSPENSIÓN: NEWAY AR-90, RL 196 SUSPENSIÓN DE AIRE</p> <p>ESPECIFICACIONES DE= 2 3/4" DI= 1 1/8" L= 5" HD= 80</p>
<p><b>BUJE LATERAL PARA SUSPENSIÓN</b> BEAM END BUSHING</p> <p><b>PBJ-4486</b></p> <p>OEM 90008139</p> 	<p><b>BUJE LATERAL PARA SUSPENSIÓN POLIURETANO</b> URETHANE BEAM END BUSHING</p> <p><b>PBJ-4486P</b></p> <p>OEM 90008139</p> 	<p><b>BUJE PARA SUSPENSIÓN</b> BEAM BUSHING</p> <p><b>PBJ-4488</b></p> <p>OEM</p> 
<p>SUSPENSIÓN: NEWAY AR41, 70, 75, 90, 95, ART500, PAGE LM-200 SUSPENSIÓN DE AIRE</p> <p>ESPECIFICACIONES DE= 3 1/2" DI= 1 1/8" L= 5 1/4"</p>	<p>SUSPENSIÓN: NEWAY AR41, 70, 75, 90, 95, ART500, PAGE LM-200 SUSPENSIÓN DE AIRE</p> <p>ESPECIFICACIONES DE= 3 1/2" DI= 1 1/8" L= 5 1/4" HD= 80</p>	<p>SUSPENSIÓN: NEWAY</p> <p>ESPECIFICACIONES DE= 3 1/2" DI= 1 1/8" L= 8 1/2"</p>
<p><b>BUJE PARA SUSPENSIÓN POLIURETANO</b> URETHANE BEAM BUSHING</p> <p><b>PBJ-4488P</b></p> <p>OEM</p> 	<p><b>BUJE LATERAL PARA SUSPENSIÓN POLIURETANO</b> URETHANE BEAM END BUSHING</p> <p><b>PBJ-4490P</b></p> <p>OEM 900 08 002</p> 	<p><b>BUJE CENTRAL PARA BALANCÍN</b> EQUALIZER BUSHING</p> <p><b>PBJ-2320</b></p> <p>OEM 0106-06</p> 
<p>SUSPENSIÓN: NEWAY</p> <p>ESPECIFICACIONES DE= 3 1/2" DI= 1 1/8" L= 8 1/2" HD= 80</p>	<p>SUSPENSIÓN: NEWAY</p> <p>ESPECIFICACIONES DE= 2 3/8" DI= 1 1/4" L= 5" HD= 80</p>	<p>SUSPENSIÓN: REYCO 73, 83</p> <p>ESPECIFICACIONES DE= 3 1/8" DI= 1" L= 4 1/2"</p>

<b>BUJE CENTRAL PARA BALANCÍN</b> EQUALIZER BUSHING	<b>BUJE CENTRAL PARA BALANCÍN POLIURETANO</b> URETHANE EQUALIZER BUSHING	<b>BUJE CENTRAL PARA BALANCÍN</b> EQUALIZER BUSHING
<b>PBJ-2321</b>	<b>PBJ-2321P</b>	<b>PBJ-2322</b>
 OEM 14713-01	 OEM 14713-01	 OEM 08363-01
SUSPENSIÓN: REYCO SERIE 101 Y 102 MODELOS 1984 EN ADELANTE	SUSPENSIÓN: REYCO SERIE 101 Y 102 MODELOS 1984 EN ADELANTE	SUSPENSIÓN: REYCO SERIE 101 Y 102 MODELOS ANTERIORES A 1984
<b>ESPECIFICACIONES</b> DE= 3 1/8" DI= 1 1/2" L= 4 1/2"	<b>ESPECIFICACIONES</b> DE= 3 1/8" DI= 1 1/2" L= 4 1/2" HD= 80	<b>ESPECIFICACIONES</b> DE= 3 1/8" DI= 1 1/2" L= 4 1/2"

<b>BUJE CENTRAL PARA BALANCÍN</b> EQUALIZER BUSHING	<b>BUJE CENTRAL PARA BALANCÍN POLIURETANO</b> URETHANE EQUALIZER BUSHING	<b>BUJE CENTRAL PARA BALANCÍN</b> EQUALIZER BUSHING
<b>PBJ-2323</b>	<b>PBJ-2323P</b>	<b>PBJ-2324</b>
 OEM 16146-01	 OEM 16146-01	 OEM 0649-02
SUSPENSIÓN: HUTCHENS 9600	SUSPENSIÓN: HUTCHENS 9600	SUSPENSIÓN: REYCO 86, 88, 89
<b>ESPECIFICACIONES</b> DE= 3 15/32" DI= 1 1/8" L= 4"	<b>ESPECIFICACIONES</b> DE= 3 15/32" DI= 1 1/8" L= 4" HD= 80	<b>ESPECIFICACIONES</b> DE= 3 15/32" DI= 1" L= 4"

<b>BUJE CENTRAL PARA BALANCÍN POLIURETANO</b> URETHANE EQUALIZER BUSHING	<b>BUJE CENTRAL PARA BALANCÍN</b> EQUALIZER BUSHING	<b>BUJE CENTRAL PARA BALANCÍN POLIURETANO</b> URETHANE EQUALIZER BUSHING
<b>PBJ-2324P</b>	<b>PBJ-2325</b>	<b>PBJ-2483P</b>
 OEM 0649-02	 OEM 08915-01	 OEM
SUSPENSIÓN: REYCO 86, 88, 89	SUSPENSIÓN: REYCO SERIE 101 Y 102	SUSPENSIÓN: REYCO
<b>ESPECIFICACIONES</b> DE= 3 15/32" DI= 1" L= 4" HD= 80	<b>ESPECIFICACIONES</b> DE= 3 1/8" DI= 1 1/4" L= 4 1/2"	<b>ESPECIFICACIONES</b> DE= 3 9/32" DI= 1" 3 7/8" HD= 80

<b>BUJE PARA BALANCÍN POLIURETANO</b> URETHANE EQUALIZER BUSHING	<b>BUJE PARA BALANCÍN</b> NYLON EQUALIZER BUSHING	<b>BUJE PARA SUSPENSION</b> HINGE BUSHING
<b>PBJ-13568P</b>	<b>PBJ-13568N</b>	<b>PBJ-1306</b>
 OEM 16-13568-000	 OEM 16-13568-000	 OEM 3-106
SUSPENSIÓN: FREIGHTLINER FH 34	SUSPENSIÓN: FREIGHTLINER FH 34	SUSPENSIÓN: UTILITY
<b>ESPECIFICACIONES</b> L= 2 1/4" DI= 2 9/32" DE1= 3 3/4" DE2= 2 3/4 HD= 80	<b>ESPECIFICACIONES</b> L= 2 1/4" DI= 2 9/32" DE1= 3 3/4" DE2= 2 3/4 HD= 95	<b>ESPECIFICACIONES</b> ANCHO= 2 7/8" DI= 1 7/8" L= 2 7/8"



<b>BUJE PARA SUSPENSIÓN POLIURETANO</b> URETHANE HINGE BUSHING		<b>BUJE CENTRAL PARA BALANCÍN</b> EQUALIZER BUSHING		<b>BUJE PARA AMORTIGUADOR POLIURETANO</b> URETHANE SHOCK ABSORBER BUSHING	
<b>PBJ-1306P</b>		<b>PBJ-1003</b>		<b>PBJ-1033P</b>	
OEM 3-106		OEM K-O66-B-163		OEM	
					
SUSPENSIÓN:	UTILITY	SUSPENSIÓN:	REYCO 21, 21B, KENWORTH	SUSPENSIÓN:	VARIOS
<b>ESPECIFICACIONES</b>		<b>ESPECIFICACIONES</b>		<b>ESPECIFICACIONES</b>	
ANCHO= 2 7/8" DI= 1 7/8" L= 2 7/8" HD= 80		A= 2 1/2" DE= 3 15/16" DI= 2 7/16"		A= 1" DI= 3/4" DE= 1 1/2" HD= 80	

<b>BUJE PARA AMORTIGUADOR</b> SHOCK ABSORBER BUSHING		<b>BUJE PARA AMORTIGUADOR POLIURETANO</b> URETHANE SHOCK ABSORBER BUSHING		<b>BUJE PARA AMORTIGUADOR POLIURETANO</b> URETHANE ABSORBER BUSHING	
<b>PBJ-1034</b>		<b>PBJ-1034P</b>		<b>PBJ-6702P</b>	
OEM K-O66-B-238		OEM K-O66-B-238		OEM 5316702	
					
SUSPENSIÓN:	FRUEHAUF, REYCO 81, NEWAY, FREIGHTLINER, MACK, PETERBILT	SUSPENSIÓN:	FRUEHAUF, REYCO, FREIGHTLINER, KENWORTH	SUSPENSIÓN:	KENWORTH
<b>ESPECIFICACIONES</b>		<b>ESPECIFICACIONES</b>		<b>ESPECIFICACIONES</b>	
A= 1" DE= 1 7/8" DI= 1"		A= 1" DE= 1 7/8" DI= 1" HD= 80		DE= 1 7/16" DI= 13/16" ALTO= 7/8" HD= 80	

<b>BUJE PARA AMORTIGUADOR POLIURETANO</b> URETHANE SHOCK ABSORBER BUSHING		<b>BUJE CÓNICO PARA TENSOR</b> TORQUE ROD BUSHING		<b>BUJE CÓNICO PARA TENSOR POLIURETANO</b> URETHANE TORQUE ROD BUSHING	
<b>PBJ-1030P</b>		<b>PBJ-1037</b>		<b>PBJ-1037P</b>	
OEM		OEM UXA-0011		OEM UXA-0011	
					
SUSPENSIÓN:	AMORTIGUADOR MONROE	SUSPENSIÓN:	FRUEHAUF, TRAILMOBILE, HUTCHENS	SUSPENSIÓN:	FRUEHAUF, TRAILMOBILE, HUTCHENS
<b>ESPECIFICACIONES</b>		<b>ESPECIFICACIONES</b>		<b>ESPECIFICACIONES</b>	
DE= 2 1/8" DI= 13/16" L= 7/8" HD= 80		DE= 2 3/16" DI= 1 1/4" L= 2 3/8"		DE= 2 3/16" DI= 1 1/4" L= 2 3/8" HD= 80	

<b>BUJE CÓNICO PARA TENSOR POLIURETANO</b> URETHANE TORQUE ROD BUSHING		<b>BUJE CÓNICO PARA BALANCÍN</b> EQUALIZER BUSHING		<b>BUJE CÓNICO PARA BALANCÍN POLIURETANO</b> URETHANE EQUALIZER BUSHING	
<b>PBJ-1037CP</b>		<b>PBJ-1038</b>		<b>PBJ-1038P</b>	
OEM UXA-0011		OEM UXA-0004		OEM UXA-0004	
					
SUSPENSIÓN:	FRUEHAUF, TRAILMOBILE, HUTCHENS	SUSPENSIÓN:	FRUEHAUF	SUSPENSIÓN:	FRUEHAUF
<b>ESPECIFICACIONES</b>		<b>ESPECIFICACIONES</b>		<b>ESPECIFICACIONES</b>	
DE= 2 3/16" DI= 1 1/4" L= 2 3/8" HD= 80 NÚCLEO INT. NYLON		DE= 3 1/2" DI= 2" L= 4 3/8"		DE= 3 1/2" DI= 2" L= 4 3/8" HD= 80	

<b>BUJE CÓNICO PARA BALANCÍN POLIURETANO</b> URETHANE EQUALIZER BUSHING		<b>BUJE CÓNICO PARA BALANCÍN</b> EQUALIZER BUSHING		<b>BUJE PARA TENSOR POLIURETANO</b> URETHANE TORQUE ROD BUSHING	
<b>PBJ-1038CP</b>		<b>PBJ-5524</b>		<b>PBJ-5524P</b>	
OEM UXA-0004		OEM T-5524		OEM T-5524	
					
SUSPENSIÓN:	FRUEHAUF	SUSPENSIÓN:	REYCO 21-B	SUSPENSIÓN:	REYCO 21-B
ESPECIFICACIONES		ESPECIFICACIONES		ESPECIFICACIONES	
DE= 3 1/2" DI= 2" L= 4 3/8" HD= 80 NÚCLEO INT. NYLON		DE= 3 1/2" DI= 1 5/8" L= 4 1/2"		DE= 3 1/2" DI= 1 5/8" L= 4 1/2" HD=80	

<b>BUJE PARA TENSOR</b> TORQUE ROD BUSHING		<b>BUJE PARA TENSOR POLIURETANO</b> URETHANE TORQUE ROD BUSHING		<b>BUJE PARA TENSOR</b> TORQUE ROD BUSHING	
<b>PBJ-1032</b>		<b>PBJ-1032P</b>		<b>PBJ-1216</b>	
OEM 3-12-6		OEM 3-12-6		OEM 3-12-16	
					
SUSPENSIÓN:	TRAILMOBILE	SUSPENSIÓN:	TRAILMOBILE	SUSPENSIÓN:	TRAILMOBILE, PARALLELOGRAM
ESPECIFICACIONES		ESPECIFICACIONES		ESPECIFICACIONES	
DE= 2 3/8" DI= 1 5/16" L= 2 1/4"		DE= 2 3/8" DI= 1 5/16" L= 2 1/4" HD= 80		DE= 2 3/8" DI= 1 5/16" L= 3"	

<b>BUJE PARA TENSOR</b> TORQUE ROD BUSHING		<b>BUJE PARA TENSOR</b> TORQUE ROD BUSHING		<b>BUJE PARA TENSOR</b> TORQUE ROD BUSHING	
<b>PBJ-1416</b>		<b>PBJ-1035</b>		<b>PBJ-1026</b>	
OEM A-1225-L-1416		OEM 412587C1, 39400013		OEM	
					
SUSPENSIÓN:	ROCKWELL	SUSPENSIÓN:	INTERNATIONAL / NAVISTAR DAYTON	SUSPENSIÓN:	INTERNATIONAL
ESPECIFICACIONES		ESPECIFICACIONES		ESPECIFICACIONES	
DE= 2 3/8" DI= 7/8" L= 3"		DE= 2 3/8" DI= 7/8" L= 3"		DE= 2 3/8" DI= 1" L= 3"	

<b>BUJE PARA TENSOR</b> TORQUE ROD BUSHING		<b>BUJE PARA TENSOR POLIURETANO</b> URETHANE TORQUE ROD BUSHING		<b>BUJE PARA TENSOR</b> TORQUE ROD BUSHING	
<b>PBJ-10117</b>		<b>PBJ-10117P</b>		<b>PBJ-10118</b>	
OEM		OEM		OEM	
					
SUSPENSIÓN:	ROCCSA	SUSPENSIÓN:	ROCCSA	SUSPENSIÓN:	ROCCSA
ESPECIFICACIONES		ESPECIFICACIONES		ESPECIFICACIONES	
DE= 1 25/32" DI= 1" L= 3"		DE= 1 25/32" DI= 1" L= 3" HD= 80		DE= 1 7/8" DI= 1" L= 3"	

<p><b>BUJE PARA TENSOR POLIURETANO</b> URETHANE TORQUE ROD BUSHING</p> <p><b>PBJ-10118P</b></p> <p>OEM</p> 	<p><b>BUJE PARA TENSOR</b> TORQUE ROD BUSHING</p> <p><b>PBJ-10119</b></p> <p>OEM L-3-12-8</p> 	<p><b>BUJE PARA TENSOR POLIURETANO</b> URETHANE TORQUE ROD BUSHING</p> <p><b>PBJ-10119P</b></p> <p>OEM L-3-12-8</p> 
<p>SUSPENSIÓN: ROCCSA</p> <p>ESPECIFICACIONES DE= 1 7/8" DI= 1" L= 3" HD= 80</p>	<p>SUSPENSIÓN: HUTCHENS</p> <p>ESPECIFICACIONES DE= 2" DI= 1" L= 3"</p>	<p>SUSPENSIÓN: HUTCHENS</p> <p>ESPECIFICACIONES DE= 2" DI= 1" L= 3" HD= 80</p>
<p><b>BUJE PARA TENSOR</b> TORQUE ROD BUSHING</p> <p><b>PBJ-10123</b></p> <p>OEM O9729-01, A-1712</p> 	<p><b>BUJE PARA TENSOR POLIURETANO</b> URETHANE TORQUE ROD BUSHING</p> <p><b>PBJ-10123P</b></p> <p>OEM O9729-01, A-1712</p> 	<p><b>BUJE PARA TENSOR</b> TORQUE ROD BUSHING</p> <p><b>PBJ-10124</b></p> <p>OEM</p> 
<p>SUSPENSIÓN: REYCO, HENDRICKSON</p> <p>ESPECIFICACIONES DE= 2" DI= 7/8" L= 3"</p>	<p>SUSPENSIÓN: REYCO, HENDRICKSON</p> <p>ESPECIFICACIONES DE= 2" DI= 7/8" L= 3" HD= 80</p>	<p>SUSPENSIÓN: ROCCSA</p> <p>ESPECIFICACIONES DE= 1 25/32" DI= 7/8" L= 3"</p>
<p><b>BUJE PARA TENSOR POLIURETANO</b> URETHANE TORQUE ROD BUSHING</p> <p><b>PBJ-10124P</b></p> <p>OEM</p> 	<p><b>BUJE PARA TENSOR</b> TORQUE ROD BUSHING</p> <p><b>PBJ-1054</b></p> <p>OEM L-3-12-7</p> 	<p><b>BUJE PARA TENSOR</b> TORQUE ROD BUSHING</p> <p><b>PBJ-3344</b></p> <p>OEM 722-00, 3-12-35</p> 
<p>SUSPENSIÓN: ROCCSA</p> <p>ESPECIFICACIONES DE= 1 25/32" DI= 7/8" L= 3" HD= 80</p>	<p>SUSPENSIÓN: ROCCSA</p> <p>ESPECIFICACIONES DE= 2" DI= 7/8" L= 3"</p>	<p>SUSPENSIÓN: TRAILMOBILE, HUTCHENS</p> <p>ESPECIFICACIONES DE= 1 15/16" DI= 1" L= 3"</p>
<p><b>BUJE PARA TENSOR POLIURETANO</b> URETHANE TORQUE ROD BUSHING</p> <p><b>PBJ-3344P</b></p> <p>OEM 722-00, 3-12-35</p> 	<p><b>BUJE PARA BALANCÍN</b> EQUALIZER BUSHING</p> <p><b>PBJ-1053</b></p> <p>OEM</p> 	<p><b>BUJE PARA TENSOR</b> TORQUE ROD BUSHING</p> <p><b>PBJ-1020</b></p> <p>OEM K-066-164</p> 
<p>SUSPENSIÓN: TRAILMOBILE, HUTCHENS</p> <p>ESPECIFICACIONES DE= 1 15/16" DI= 1" L= 3" HD= 80</p>	<p>SUSPENSIÓN: ROCCSA</p> <p>ESPECIFICACIONES DE= 3 1/8" DI= 2" L= 3 7/8"</p>	<p>SUSPENSIÓN: REYCO, KENWORTH</p> <p>ESPECIFICACIONES DE 1= 1 3/4" DE 2= 2 3/16" DI= 1" L= 2 5/8"</p>

<b>BUJE PARA TENSOR</b> TORQUE ROD BUSHING		<b>BUJE PARA TENSOR</b> TORQUE ROD BUSHING		<b>BUJE PARA TENSOR POLIURETANO</b> URETHANE TORQUE ROD BUSHING	
<b>PBJ-1024</b>		<b>PBJ-2290</b>		<b>PBJ-2290P</b>	
OEM 222-00		OEM T-5493		OEM T-5493	
					
SUSPENSIÓN:	HUTCHENS H200	SUSPENSIÓN:	REYCO 21-B	SUSPENSIÓN:	REYCO 21-B
<b>ESPECIFICACIONES</b>		<b>ESPECIFICACIONES</b>		<b>ESPECIFICACIONES</b>	
DE 1= 1 3/4" DE 2= 2 1/16" DI= 1" L= 3"		DE 1= 1 13/16" DE 2= 2 1/4" DI= 1" L= 3"		DE 1= 1 13/16" DE 2= 2 1/4" DI= 1" L= 3" HD= 80	

<b>BUJE PARA TENSOR</b> TORQUE ROD BUSHING		<b>BUJE PARA TENSOR</b> TORQUE ROD BUSHING		<b>BUJE PARA TENSOR POLIURETANO</b> URETHANE TORQUE ROD BUSHING	
<b>PBJ-2290SC</b>		<b>PBJ-3379</b>		<b>PBJ-3379P</b>	
OEM T-5493		OEM T-2242		OEM T-2242	
					
SUSPENSIÓN:	REYCOO SERIE 21	SUSPENSIÓN:	REYCO 21, 102 DANA 36, 55	SUSPENSIÓN:	REYCO 21, 102 DANA 36, 55
<b>ESPECIFICACIONES</b>		<b>ESPECIFICACIONES</b>		<b>ESPECIFICACIONES</b>	
DE 1= 1 13/16" DE 2= 2 1/4" DI= 1" L= 3"		DE 1= 1 3/4" DE 2= 2 3/8" DI= 1" L= 2 11/16"		DE 1= 1 3/4" DE 2= 2 3/8" DI= 1" L= 2 11/16" HD= 80	

<b>BUJE PARA TENSOR</b> TORQUE ROD BUSHING		<b>BUJE PARA TENSOR</b> TORQUE ROD BUSHING		<b>BUJE CONCÉNTRICO PARA TENSOR</b> TORQUE ROD BUSHING	
<b>PBJ-3379SC</b>		<b>PBJ-1057</b>		<b>PBJ-1058</b>	
OEM T-2242		OEM 563400		OEM T-1842	
					
SUSPENSIÓN:	REYCO SERIE 100	SUSPENSIÓN:	FRUEHAUF RR-55, RAMÍREZ	SUSPENSIÓN:	REYCO 101, 102
<b>ESPECIFICACIONES</b>		<b>ESPECIFICACIONES</b>		<b>ESPECIFICACIONES</b>	
DE 1= 1 3/4" DE 2= 2 3/8" DI= 1" L= 2 11/16"		DE= 2 DI= 1 1/4" L= 2 3/8"		DE 1= 1 13/16" DE 2= 3 1/16" DI= 1 1/16" L= 2 7/8"	

<b>BUJE CONCÉNTRICO PARA TENSOR POLIURETANO</b> URETHANE TORQUE ROD BUSHING		<b>BUJE EXCÉNTRICO PARA TENSOR</b> TORQUE ROD BUSHING		<b>BUJE EXCÉNTRICO PARA TENSOR POLIURETANO</b> URETHANE TORQUE ROD BUSHING	
<b>PBJ-1058P</b>		<b>PBJ-1059</b>		<b>PBJ-1059P</b>	
OEM T-1842		OEM T-1723		OEM T-1723	
					
SUSPENSIÓN:	REYCO 101, 102	SUSPENSIÓN:	REYCO 101, 102, 201	SUSPENSIÓN:	REYCO 101, 102, 201
<b>ESPECIFICACIONES</b>		<b>ESPECIFICACIONES</b>		<b>ESPECIFICACIONES</b>	
DE 1= 1 13/16" DE 2= 3 1/16" DI= 1 1/16" L= 2 7/8" HD= 80		DE 1= 1 13/16" DE 2= 3 1/16" DI= 1 1/16" L= 2 7/8"		DE 1= 1 13/16" DE 2= 3 1/16" DI= 1 1/16" L= 2 7/8" HD= 80	

<p><b>BUJE PARA TENSOR 1 X 2 X 3</b> TORQUE ROD BUSHING</p>	<p><b>BUJE PARA TENSOR 1 X 2 X 3</b> TORQUE ROD BUSHING</p>	<p><b>BUJE PARA TENSOR 1 X 2 X 3 POLIURETANO</b> URETHANE TORQUE ROD BUSHING</p>
<p><b>PBJ-10129</b></p>	<p><b>PBJ-10129-C</b></p>	<p><b>PBJ-10129-CP</b></p>
<p>OEM</p> 	<p>OEM</p> 	<p>OEM</p> 
<p>SUSPENSIÓN: UNIVERSAL</p>	<p>SUSPENSIÓN: UNIVERSAL</p>	<p>SUSPENSIÓN: UNIVERSAL</p>
<p><b>ESPECIFICACIONES</b> DE= 2" DI= 1" L= 3"</p>	<p><b>ESPECIFICACIONES</b> DE= 2" DI= 1" L= 3" CON CASQUILLO / INNER METAL SLEEVE</p>	<p><b>ESPECIFICACIONES</b> DE= 2" DI= 1" L= 3" HD= 80 CON CASQUILLO / INNER METAL SLEEVE</p>
<p><b>TOPE PARA DEFENSA TRASERA</b> BUMPER</p>	<p><b>TOPE PARA DEFENSA TRASERA POLIURETANO</b> URETHANE BUMPER</p>	<p><b>TOPE PARA DEFENSA TRASERA</b> BUMPER</p>
<p><b>PBJ-1060</b></p>	<p><b>PBJ-1060P</b></p>	<p><b>PBJ-1061P</b></p>
<p>OEM</p> 	<p>OEM</p> 	<p>OEM</p> 
<p>SUSPENSIÓN: UNIVERSAL</p>	<p>SUSPENSIÓN: UNIVERSAL</p>	<p>SUSPENSIÓN: HYUNDAI</p>
<p><b>ESPECIFICACIONES</b> ALTURA= 3 7/16" ANCHO= 4" LARGO= 6"</p>	<p><b>ESPECIFICACIONES</b> ALTURA= 3 7/16" ANCHO= 4" LARGO= 6" HD= 80</p>	<p><b>ESPECIFICACIONES</b> ALTURA= 86mm ANCHO= 74mm LARGO= 153mm HD= 80</p>
<p><b>TOPE PARA DEFENSA</b> BUMPER</p>	<p><b>BUJE PARA CANILLA DE SUSPENSIÓN</b> TORQUE ROD BUSHING</p>	<p><b>BUJE PARA CANILLA DE SUSPENSIÓN</b> TORQUE ROD BUSHING</p>
<p><b>PBJ-1062</b></p>	<p><b>PBJ-1064</b></p>	<p><b>PBJ-1065</b></p>
<p>OEM</p> 	<p>OEM</p> 	<p>OEM</p> 
<p>SUSPENSIÓN: UNIVERSAL</p>	<p>SUSPENSIÓN: RAMÍREZ, SULTANA</p>	<p>SUSPENSIÓN: MASA, SOMEX</p>
<p><b>ESPECIFICACIONES</b> ALTO= 3 1/2" ANCHO= 2 15/16" LARGO= 5 15/32"</p>	<p><b>ESPECIFICACIONES</b> DE= 3 5/8" DI= 2 7/16" L= 3"</p>	<p><b>ESPECIFICACIONES</b> DE= 3" DI= 1 3/4" L= 2 7/8"</p>
<p><b>BUJE PARA SUSPENSIÓN</b> TORQUE ROD BUSHING</p>	<p><b>BUJE PARA SUSPENSIÓN</b> TORQUE ROD BUSHING</p>	<p><b>SOPORTE PARA MUELLE</b> RUBBER METAL PAD</p>
<p><b>PBJ-2005</b></p>	<p><b>PBJ-2460</b></p>	<p><b>PBJ-D89</b></p>
<p>OEM</p> 	<p>OEM</p> 	<p>OEM 1591299</p> 
<p>SUSPENSIÓN: TENSOR DE DIFERENCIAL</p>	<p>SUSPENSIÓN: TENSOR DE DIFERENCIAL</p>	<p>SUSPENSIÓN: VOLVO SUSPENSIÓN DE MUELLE DELANTERA SERIES WF, WC, WH</p>
<p><b>ESPECIFICACIONES</b> DE= 2 5/8" DI= 2" L= 2 13/16"</p>	<p><b>ESPECIFICACIONES</b> DE= 1 7/8" DI= 1 1/4" L= 2 1/2"</p>	<p><b>ESPECIFICACIONES</b> DB= 3/8" L= 4" ANCHO= 3 1/4" ESPESOR= 1/2"</p>

<b>BUJE PARA SUSPENSIÓN NEWAY</b> RUBBER PAD		<b>BUJE PARA SUSPENSION NEWAY POLIURETANO</b> URETHANE PAD		<b>SOPORTE PARA MUELLE POLIURETANO</b> URETHANE PAD	
<b>PBJ-91028013</b>		<b>PBJ-91028013P</b>		<b>PBJ-5635P</b>	
OEM 91028013		OEM 91028013		OEM UCD5635-001	
					
SUSPENSIÓN:	NEWAY	SUSPENSIÓN:	NEWAY	SUSPENSIÓN:	FRUEHAUF
<b>ESPECIFICACIONES</b>		<b>ESPECIFICACIONES</b>		<b>ESPECIFICACIONES</b>	
L= 5 1/4" ANCHO= 4 5/8" ESPESOR= 5/8"		L= 5 1/4" ANCHO= 4 5/8" ESPESOR= 5/8" HD = 80		ANCHO= 4 3/4" ESPESOR= 1" L= 7 5/8" HD= 80	

<b>BUJE PARA MUELLE</b> RUBBER BUSHING		<b>BUJE PARA MUELLE</b> RUBBER SHACKLE BUSHING		<b>BUJE PARA MUELLE</b> SPRING BUSHING	
<b>PBJ-HB1003</b>		<b>PBJ-HB389</b>		<b>PBJ-1055</b>	
OEM HB1003		OEM HARRIS 08009		OEM 32028	
					
SUSPENSIÓN:	CROWN COACH	SUSPENSIÓN:		SUSPENSIÓN:	VAN-HOOL-NEOPLAN
<b>ESPECIFICACIONES</b>		<b>ESPECIFICACIONES</b>		<b>ESPECIFICACIONES</b>	
DE= 2 1/4" DI= 1 1/4" L= 2 11/16"		DE 1= 1" DE 2= 1 1/4" DI= 1/2" L= 1 7/16"		DE= 2 9/16" DI= 1 3/16" L= 4"	

<b>BUJE PARA MUELLE</b> SPRING RUBBER BUSHING		<b>BUJE PARA MUELLE</b> SPRING RUBBER BUSHING		<b>BUJE PARA MUELLE</b> SPRING RUBBER BUSHING	
<b>PBJ-201</b>		<b>PBJ-202</b>		<b>PBJ-235</b>	
OEM 5504701G10		OEM 5504531G00		OEM	
					
SUSPENSIÓN:	RB-201 NISSAN	SUSPENSIÓN:	RB-202 TOYOTA	SUSPENSIÓN:	RB-235 REYCO
<b>ESPECIFICACIONES</b>		<b>ESPECIFICACIONES</b>		<b>ESPECIFICACIONES</b>	
DE= 1.250" DI= 0.472" (12mm) L= 2.750"		DE= 1.570" DI= 0.709" (18mm) L= 2.750"		DE= 1 3/4" DI= 0.709" (18mm) L= 3 1/2"	

<b>BUJE PARA MUELLE</b> SPRING RUBBER BUSHING		<b>BUJE PARA MUELLE</b> SPRING RUBBER BUSHING		<b>BUJE PARA MUELLE</b> SPRING RUBBER BUSHING	
<b>PBJ-236</b>		<b>PBJ-243</b>		<b>PBJ-244</b>	
OEM		OEM		OEM	
					
SUSPENSIÓN:	RB-236 REYCO	SUSPENSIÓN:	RB-243	SUSPENSIÓN:	RB-244 FORD
<b>ESPECIFICACIONES</b>		<b>ESPECIFICACIONES</b>		<b>ESPECIFICACIONES</b>	
DE= 1 3/8" DI= 0.551" (14mm) L= 3"		DE= 1 7/8" DI= 0.787" (20mm) L= 3 1/2"		DE= 1 3/4" DI= 0.630" (16mm) L= 3 1/2"	

<b>BUJE PARA MUELLE</b> SPRING RUBBER BUSHING	<b>BUJE PARA MUELLE</b> RUBBER BUSHING	<b>BUJE PARA MUELLE</b> SPRING RUBBER BUSHING
<b>PBJ-245</b>	<b>PBJ-246</b>	<b>PBJ-247</b>
 OEM	 OEM 97074826, RB 246	 OEM
SUSPENSIÓN: RB-245 FORD	SUSPENSIÓN: ISUZU GM	SUSPENSIÓN: NISSAN
<b>ESPECIFICACIONES</b> DE= 2 3/16" DI= 0.709" (18mm) L= 3 1/2"	<b>ESPECIFICACIONES</b> DE= 1 21/32" DI= 23/32" L= 3 3/16"	<b>ESPECIFICACIONES</b> DE= 1 1/14" DI= 35/64" L= 2 1/2"

<b>COJÍN SEPARADOR</b> RUBBER PAD	<b>BUJE PARA SUSPENSION</b> RUBBER BUSHING	<b>BUJE PARA MUELLE</b> RUBBER SHACKLE BUSHING
<b>PBJ-8059664</b>	<b>PBJ-ASTRBO01</b>	<b>PBJ-SB-O395</b>
 OEM 8059664	 OEM	 OEM
SUSPENSIÓN: VOLVO "T-RIDE"	SUSPENSIÓN: CHEVROLET TRASERA ASTRO	SUSPENSIÓN:
<b>ESPECIFICACIONES</b> ALTO= 1 3/16" ANCHO= 1 3/16" LARGO= 1 11/16"	<b>ESPECIFICACIONES</b> DE= 2 15/32" DI= 1 17/32" L= 1 15/16"	<b>ESPECIFICACIONES</b> DE 1= 2" DE 2= 2 1/4" DI= 11/16" L= 1 3/16"

<b>BUJE PARA MUELLE</b> SHACKLE BUSHING	<b>BUJE PARA MUELLE</b> SHACKLE BUSHING	<b>BUJE PARA MUELLE</b> SHACKLE BUSHING
<b>PBJ-SB1004</b>	<b>PBJ-SB1101</b>	<b>PBJ-SB2001</b>
 OEM 90385-18001	 OEM 90385-18018	 OEM 55045-10W00, 55047-20400
SUSPENSIÓN: TOYOTA	SUSPENSIÓN: TOYOTA	SUSPENSIÓN: TOYOTA
<b>ESPECIFICACIONES</b> DE1= 1.160" (29.46mm) DE2= 1.355" (34.417mm) DI= 0.700" (17.78mm) L= 1.475" (37.465mm)	<b>ESPECIFICACIONES</b> DE1= 1.365" (34.67mm) DE2= 1.550" (39.37mm) DI= 0.700" (17.7mm) L= 1.475" (37.465mm)	<b>ESPECIFICACIONES</b> DE1= 1.570" (39.88mm) DE2= 1.815" (46.101mm) DI= 0.710" (18.034mm) L= 1.500" (38.10mm)

<b>BUJE TRASERO PARA MUELLE POLIURETANO</b> URETHANE REAR SHACKLE BUSHING	<b>BUJE PARA MUELLE</b> SHACKLE BUSHING	<b>BUJE DELANTERO PARA MUELLE POLIURETANO</b> URETHANE FRONT SHACKLE BUSHING
<b>PBJ-SB2001P</b>	<b>PBJ-SB2002</b>	<b>PBJ-SB2002P</b>
 OEM 55045-10W00, 55047-20400	 OEM 55046-01G00, 55045-H1000	 OEM 55046-01G00, 55045-H1000
SUSPENSIÓN: NISSAN	SUSPENSIÓN: NISSAN	SUSPENSIÓN: NISSAN
<b>ESPECIFICACIONES</b> DE= 1 9/16" DI= 3/4" L= 1 13/32" HD= 80	<b>ESPECIFICACIONES</b> DE1= 1.280" (32.51mm) DE2= 1.500" (38.10mm) DI= 0.795" (20.193mm) L= 1.475" (37.465mm)	<b>ESPECIFICACIONES</b> DE 1= 1 19/64" DI= 3/4" L= 13/32" HD= 80

<b>BUJE PARA MUELLE DELANTERA</b> FRONT SHACKLE BUSHING		<b>BUJE PARA MUELLE POLIURETANO</b> URETHANE SHACKLE BUSHING		<b>BUJE PARA MUELLE</b> SHACKLE BUSHING	
<b>PBJ-SB2003</b>		<b>PBJ-SB2004P</b>		<b>PBJ-SB2005</b>	
OEM MB-025153		OEM 55047-20400		OEM	
					
SUSPENSIÓN:	MITSUBISHI FUSO, FE	SUSPENSIÓN:	NISSAN	SUSPENSIÓN:	PICKUP Y SUV ISUZU
<b>ESPECIFICACIONES</b>		<b>ESPECIFICACIONES</b>		<b>ESPECIFICACIONES</b>	
DE1= 1.525" (38.74mm) DE2= 1.870" (47.498mm)		DE= 1 9/16" DI= 11/16" L= 1 13/32" HD= 80		DE 1= 1" DE 2= 1 1/4" DI= 1/2" L= 1 7/16"	

<b>BUJE PARA MUELLE POLIURETANO</b> URETHANE SHACKLE BUSHING		<b>BUJE PARA MUELLE</b> RUBBER SHACKLE BUSHING		<b>BUJE PARA MUELLE</b> RUBBER SHACKLE BUSHING	
<b>PBJ-SB2005P</b>		<b>PBJ-SB2006</b>		<b>PBJ-SB2010</b>	
OEM 55045-H1000		OEM		OEM	
					
SUSPENSIÓN:	NISSAN	SUSPENSIÓN:	PICKUP Y SUV MITSUBISHI	SUSPENSIÓN:	NISSAN FRONTIER
<b>ESPECIFICACIONES</b>		<b>ESPECIFICACIONES</b>		<b>ESPECIFICACIONES</b>	
DE= 1 9/64" DI= 5/8" L= 1 13/32" HD= 80		DE 1= 1 1/16" DE 2= 1 13/32" DI= 5/8" L= 1 1/2"		DE 1= 1 9/32" DE 2= 1 5/8" DI= 25/32" L= 1 1/2"	

<b>BUJE PARA MUELLE</b> RUBBER SHACKLE BUSHING		<b>BUJE PARA MUELLE</b> RUBBER SHACKLE BUSHING		<b>BUJE PARA MUELLE</b> RUBBER SHACKLE BUSHING	
<b>PBJ-SB2012</b>		<b>PBJ-SB2014</b>		<b>PBJ-SB2015</b>	
OEM		OEM		OEM	
					
SUSPENSIÓN:	NISSAN UD	SUSPENSIÓN:	PICK UP Y SUV ISUZU	SUSPENSIÓN:	PICK UP Y SUV MITSUBISHI
<b>ESPECIFICACIONES</b>		<b>ESPECIFICACIONES</b>		<b>ESPECIFICACIONES</b>	
DE 1= 1 9/32" DE 2= 1 1/2" DI= 25/32" L= 1 3/4"		DE 1= 1 9/16" DE 2= 1 25/32" DI= 25/32" L= 1 3/8"		DE 1= 1 1/4" DE 2= 1 1/2" DI= 11/16" L= 1 3/4"	

<b>BUJE PARA MUELLE POLIURETANO</b> URETHANE SHACKLE BUSHING		<b>BUJE PARA MUELLE POLIURETANO</b> URETHANE SHACKLE BUSHING		<b>BUJE PARA MUELLE</b> SPRING RUBBER BUSHING	
<b>PBJ-SB2020P</b>		<b>PBJ-SB2021P</b>		<b>PBJ-O5101</b>	
OEM 2404		OEM 2405		OEM 03-05101	
					
SUSPENSIÓN:	NISSAN	SUSPENSIÓN:	NISSAN	SUSPENSIÓN:	PETERBILT LOW MOUNT AIR LEAF
<b>ESPECIFICACIONES</b>		<b>ESPECIFICACIONES</b>		<b>ESPECIFICACIONES</b>	
DE= 2 1/8" DI= 21/32" L= 23/32" HD= 80		DE= 1 13/32" DI= 5/8" L= 1 27/32" HD= 80		DE= 2 1/2" DI= 1 3/4" L= 2 15/32"	



<p><b>BUJE PARA MUELLE POLIURETANO</b> URETHANE SPRING BUSHING</p> <p><b>PBJ-05101P</b></p> <p>OEM 03-05101</p> 	<p><b>BUJE PARA MUELLE</b> SPRING BUSHING</p> <p><b>PBJ-05102</b></p> <p>OEM 03-05102</p> 	<p><b>BUJE PARA MUELLE</b> SPRING RUBBER BUSHING</p> <p><b>PBJ-01674</b></p> <p>OEM 03-01674</p> 
<p>SUSPENSIÓN: PETERBILT LOW MOUNT AIR LEAF</p> <p><b>ESPECIFICACIONES</b> DE= 2 1/2" DI= 1 3/4" L= 2 15/32" HD= 80</p>	<p>SUSPENSIÓN: PETERBILT</p> <p><b>ESPECIFICACIONES</b> DE= 1 3/4" DI= 1" L= 5 3/4"</p>	<p>SUSPENSIÓN: PETERBILT AIR LEAF</p> <p><b>ESPECIFICACIONES</b> DE= 2 1/2" DI= 1 3/4" L= 2 3/4"</p>
<p><b>BUJE PARA MUELLE POLIURETANO</b> URETHANE SPRING BUSHING</p> <p><b>PBJ-01674P</b></p> <p>OEM 03-01674</p> 	<p><b>RONDANA PARA MUELLE</b> SPRING EYE WASHER</p> <p><b>PBJ-01675N</b></p> <p>OEM 03-01675</p> 	<p><b>BUJE PARA AMORTIGUADOR POLIURETANO</b> URETHANE SHOCK ABSORBER BUSHING</p> <p><b>PBJ-1040P</b></p> <p>OEM</p> 
<p>SUSPENSIÓN: PETERBILT AIR LEAF</p> <p><b>ESPECIFICACIONES</b> DE= 2 1/2" DI= 1 3/4" L= 2 3/4" HD= 80</p>	<p>SUSPENSIÓN: PETERBILT</p> <p><b>ESPECIFICACIONES</b> DE= 2 5/8" DI= 1 25/32" L= 31/32" HD= 95</p>	<p>SUSPENSIÓN: AUTOBÚS NEOPLAN</p> <p><b>ESPECIFICACIONES</b> DE= 1 9/16" DI= 3/4" L= 1 3/4" HD= 80</p>
<p><b>BUJE PARA AMORTIGUADOR POLIURETANO</b> URETHANE SHOCK ABSORBER BUSHING</p> <p><b>PBJ-1041P</b></p> <p>OEM</p> 	<p><b>TOPE PARA MUELLE</b> SPRING BUMPER</p> <p><b>PBJ-PAD102</b></p> <p>OEM C134-4002-AA</p> 	<p><b>BUJE PARA VIGA SILENT DRIVE POLIURETANO</b> URETHANE BEAM BUSHING</p> <p><b>PBJ-B3000P</b></p> <p>OEM PB3000</p> 
<p>SUSPENSIÓN:</p> <p><b>ESPECIFICACIONES</b> DE= 1 9/16" DI= 3/4" L= 1 3/4" HD= 80</p>	<p>SUSPENSIÓN: VOLVO - WHITE</p> <p><b>ESPECIFICACIONES</b> DB= 10mm ALTURA= 4 7/8" ANCHO= 2 7/16"</p>	<p>SUSPENSIÓN: SILENT DRIVE</p> <p><b>ESPECIFICACIONES</b> DE= 2 1/4" DI= 1" L= 5" HD= 80</p>
<p><b>BUJE TRASERO PARA SUSPENSION POLIURETANO</b> REAR BUSHING URETHANE</p> <p><b>PBJ-5708P</b></p> <p>OEM T-5708</p> 	<p><b>BUJE PARA PUNTA DE MUELLE POLIURETANO</b> URETHANE SPRING END BOOT</p> <p><b>PBJ-G34P</b></p> <p>OEM G34 PL-1082</p> 	<p><b>BUJE PARA PUNTA DE MUELLE POLIURETANO</b> URETHANE SPRING END BOOT</p> <p><b>PBJ-G35P</b></p> <p>OEM G35 PL-1083</p> 
<p>SUSPENSIÓN: REYCO</p> <p><b>ESPECIFICACIONES</b> DE= 1 5/8" DI= 7/8" L= 2 13/16" HD= 80</p>	<p>SUSPENSIÓN: SILVER EAGLE DOLLY</p> <p><b>ESPECIFICACIONES</b> DI= 1" LARGO= 5 1/2" ANCHO= 2 3/8" HD= 80</p>	<p>SUSPENSIÓN: SILVER EAGLE DOLLY</p> <p><b>ESPECIFICACIONES</b> DI= 1" LARGO= 5 1/2" ANCHO= 2 3/8" HD= 80</p>

<b>BUJE PARA SUSPENSION POLIURETANO</b> URETHANE BUSHING		<b>BUJE PARA TENSOR POLIURETANO</b> URETHANE TORQUE ROD BUSHING		<b>BUJE PARA TENSOR POLIURETANO</b> URETHANE TORQUE ROD BUSHING	
<b>PBJ-400329P</b> OEM 400-329		<b>PBJ-72200P</b> OEM 722-00 3-12-35		<b>PBJ-9729P</b> OEM 09729-01	
					
SUSPENSION:	HYSTER	SUSPENSION:	HUTCH	SUSPENSION:	BINKLEY
<b>ESPECIFICACIONES</b> DI= 3" DE= 5 5/8" ALTO= 2 7/8" HD = 80		<b>ESPECIFICACIONES</b> DI= 1" DE1= 1 3/4" DE2= 2" LARGO=3 HD = 80		<b>ESPECIFICACIONES</b> DI= 7/8 DE1= 1 3/4" DE2= 2 1/4" LARGO= 3" HD = 80	

**PARBO** M.R.  
PARTES PARA SUSPENSION

*PARA UN MANEJO SUAVE*®

H/CH 7700/9700  
H42-1/2", 44", 49, 54-1/2" AXLE SPACING  
TRAILER FOUR SPRING SUSPENSIONS

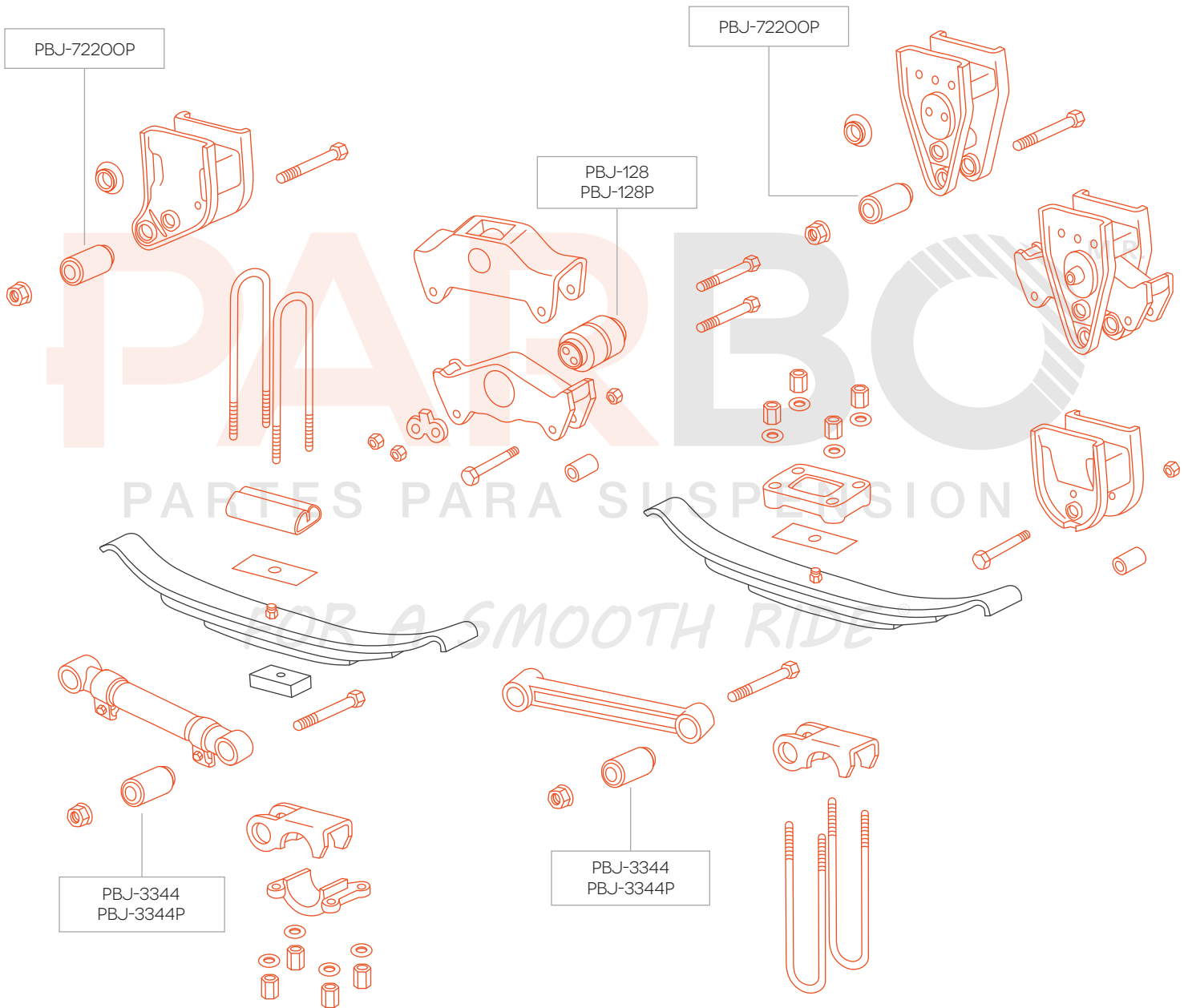

CONSULTE MÁS DIAGRAMAS DE SUSPENSIÓN EN NUESTRO SITIO WEB: [WWW.PARBO.COM.MX](http://WWW.PARBO.COM.MX)

AR/90/90-1/92/93/250  
ARU92/93  
TRAILER AIR SUSPENSIONS

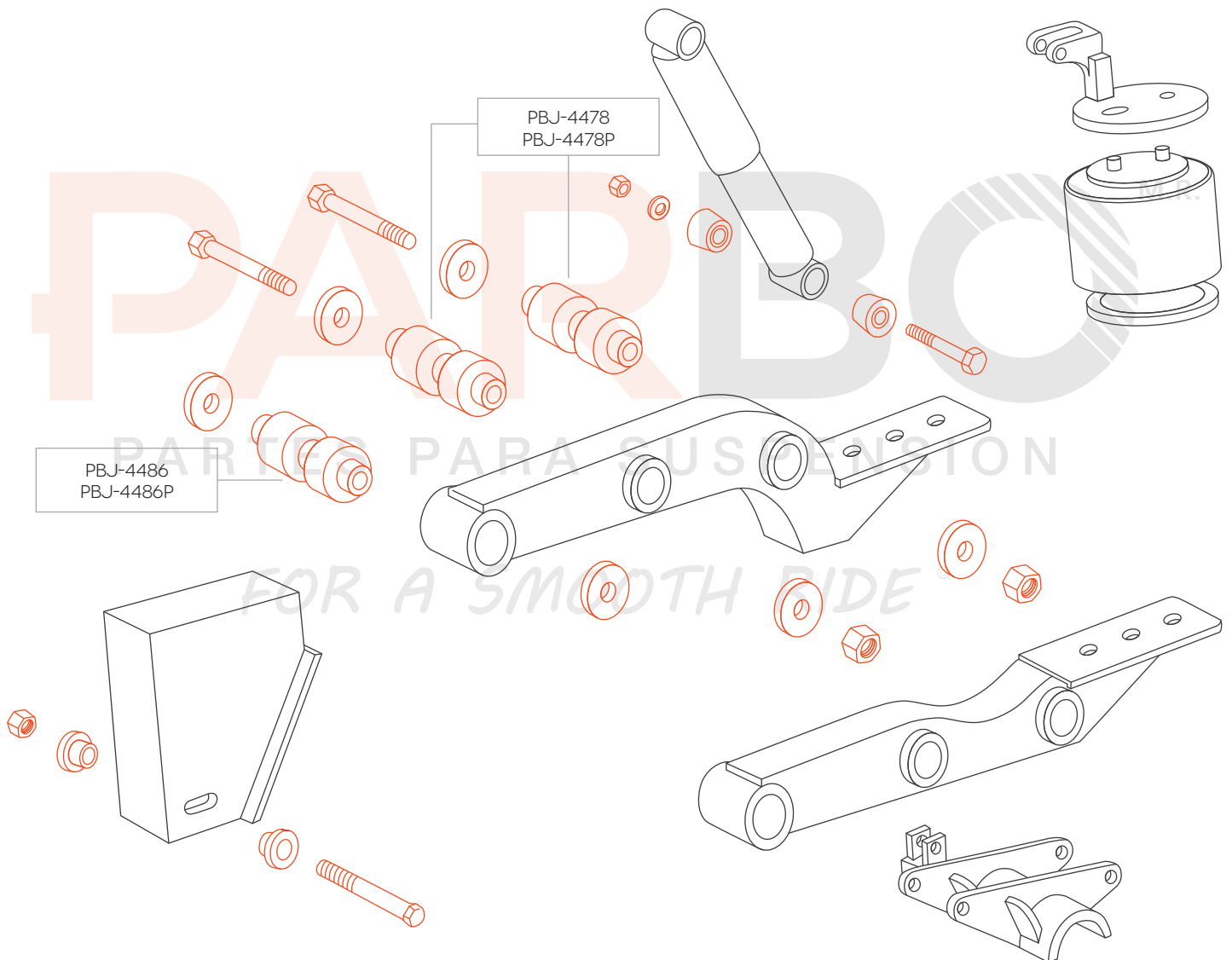

CONSULTE MÁS DIAGRAMAS DE SUSPENSION EN NUESTRO SITIO WEB: [WWW.PARBO.COM.MX](http://WWW.PARBO.COM.MX)

## NISSAN REAR SUSPENSION

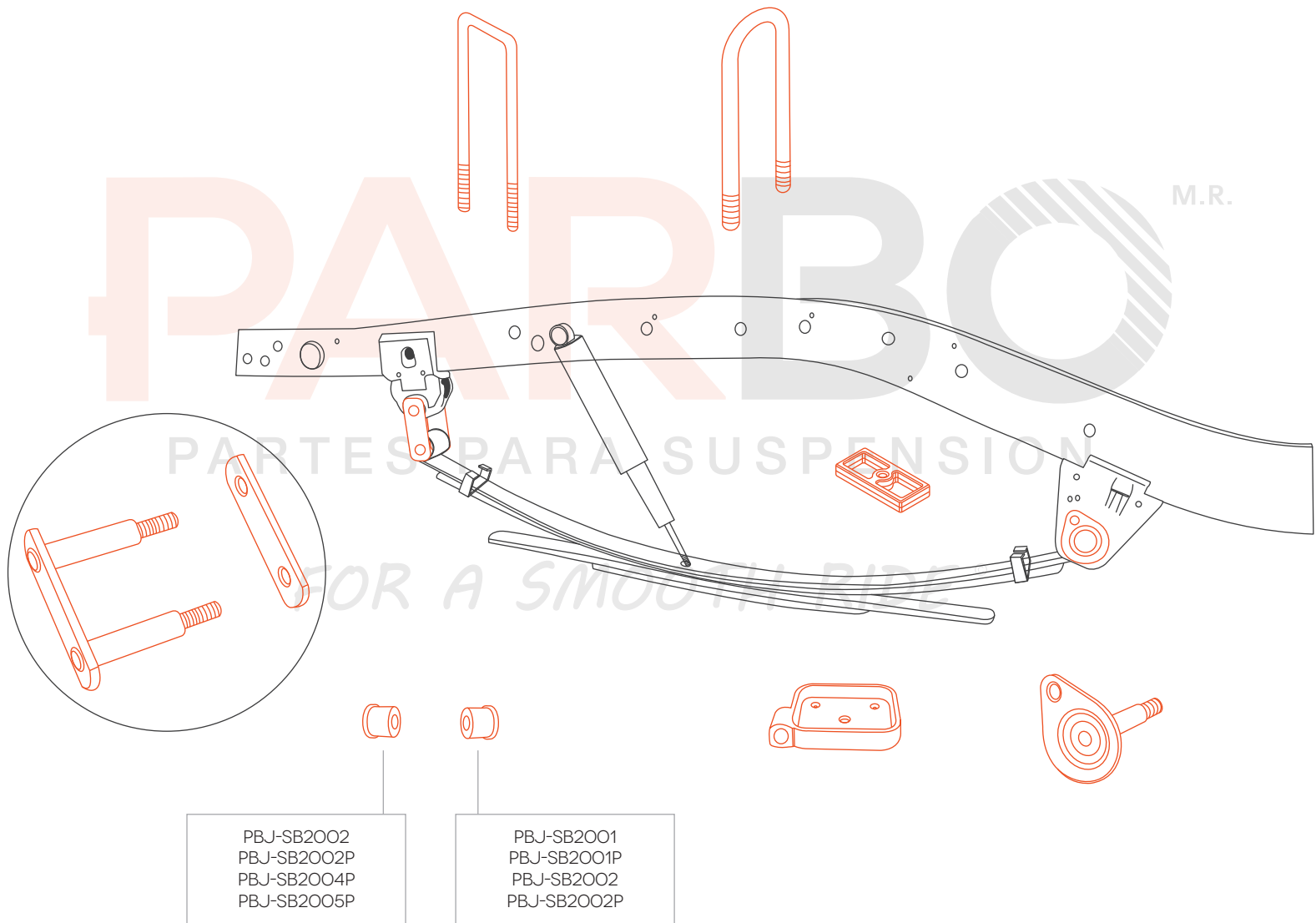

CONSULTE MÁS DIAGRAMAS DE SUSPENSION EN NUESTRO SITIO WEB: [WWW.PARBO.COM.MX](http://WWW.PARBO.COM.MX)

MODEL 102  
TRACTOR FOUR SPRING SUSPENSIONS  
(TORQUE RODS)

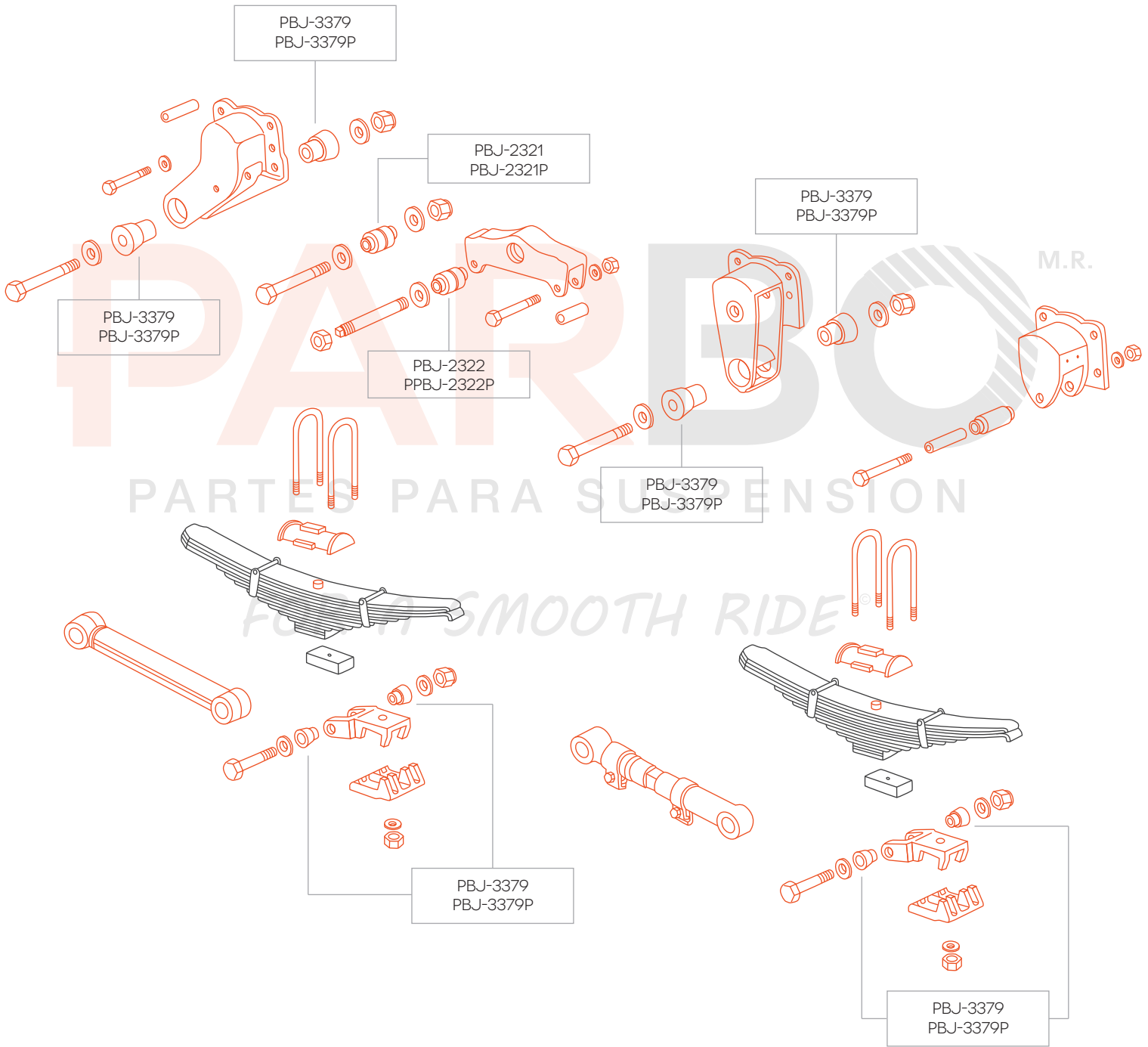

CONSULTE MÁS DIAGRAMAS DE SUSPENSION EN NUESTRO SITIO WEB: [WWW.PARBO.COM.MX](http://WWW.PARBO.COM.MX)

102AR  
SINGLE/TANDEM AXLE  
TRACTOR AIR SUSPENSION

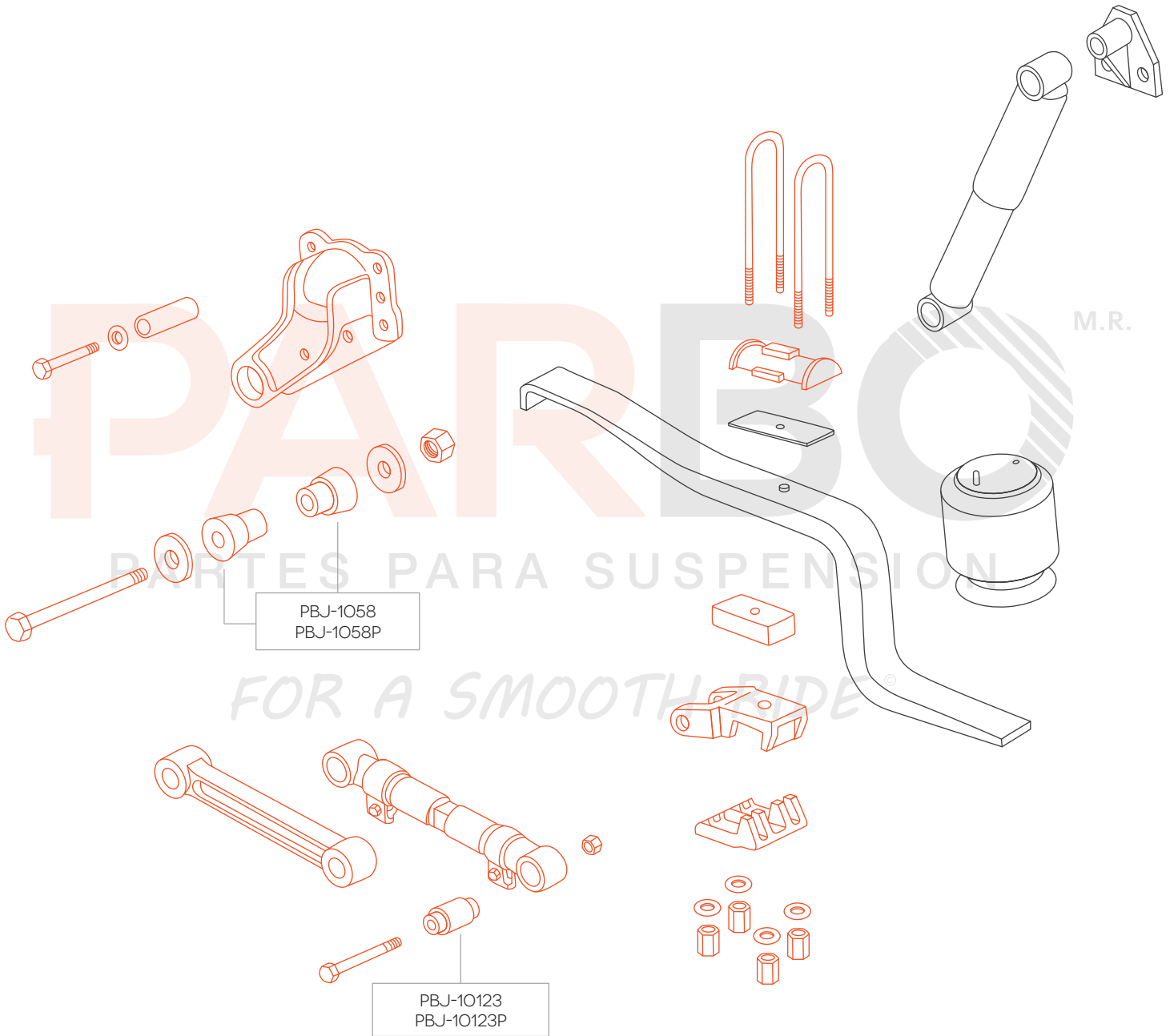

CONSULTE MÁS DIAGRAMAS DE SUSPENSIÓN EN NUESTRO SITIO WEB: [WWW.PARBO.COM.MX](http://WWW.PARBO.COM.MX)

"F" SERIES  
TRAILER FOUR SPRING SUSPENSIONS

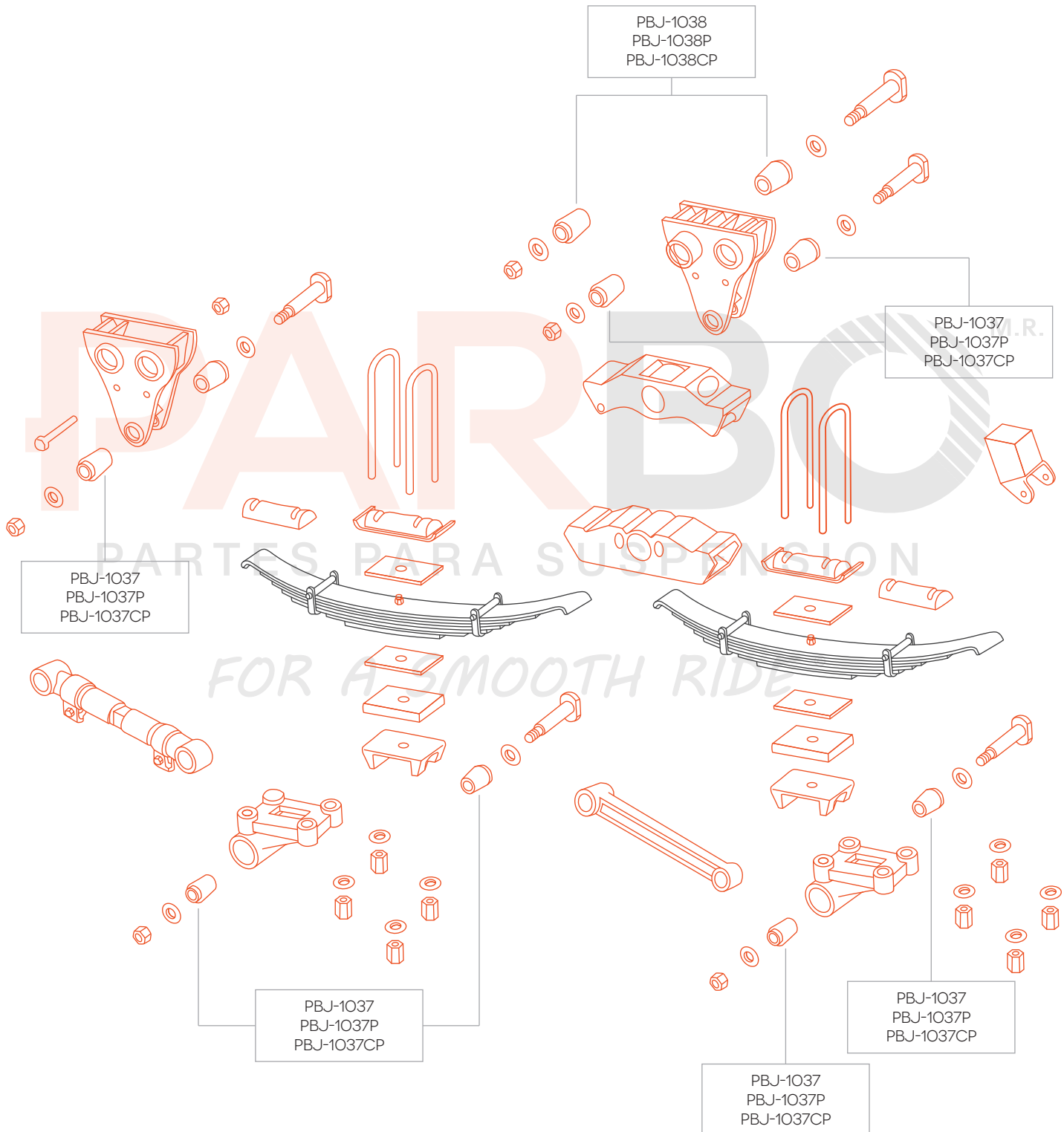

CONSULTE MÁS DIAGRAMAS DE SUSPENSION EN NUESTRO SITIO WEB: [WWW.PARBO.COM.MX](http://WWW.PARBO.COM.MX)



**CORBATAS, CODOS  
Y COPLES FLEXIBLES  
DE ADMISIÓN**  
**AIR INTAKE RUBBER  
HOSES AND ELBOWS**

**PARBO**<sup>M.R.</sup>  
PARTES PARA SUSPENSION  
*PARA UN MANEJO SUAVE*

<b>CODO DE 4.0" A 90°</b> RUBBER ELBOW <b>409040</b>  OEM	<b>CODO DE 5.0" A 90°</b> RUBBER ELBOW <b>509050</b>  OEM	<b>CODO DE 5.5" A 90°</b> RUBBER ELBOW <b>559055</b>  OEM
SUSPENSIÓN:	SUSPENSIÓN:	SUSPENSIÓN:
ESPECIFICACIONES DE= 4.0" DS= 4.0" ÁNGULO= 90°	ESPECIFICACIONES DE= 5.0" DS= 5.0" ÁNGULO= 90°	ESPECIFICACIONES DE= 5.5" DS= 5.5" ÁNGULO= 90°

<b>CODO DE 5.5" A 90°</b> RUBBER ELBOW <b>559055-L</b>  OEM	<b>CODO DE 6.0" A 90°</b> RUBBER ELBOW <b>609060</b>  OEM	<b>CODO REDUCCIÓN DE 7.0" A 5.0" A 90°</b> RUBBER REDUCER ELBOW <b>709050</b>  OEM
SUSPENSIÓN:	SUSPENSIÓN:	SUSPENSIÓN:
ESPECIFICACIONES DE= 5.5" DS= 5.5" ÁNGULO= 90°	ESPECIFICACIONES DE= 6.0" DS= 6.0" ÁNGULO= 90°	ESPECIFICACIONES DE= 7.0" DS= 5.0" ÁNGULO= 90°

<b>CODO REDUCCIÓN DE 6.0" A 5.5" A 90°</b> RUBBER REDUCER ELBOW <b>604555</b>  OEM	<b>COPLE DE 4.0"</b> RUBBER HUMP HOSE <b>400040</b>  OEM 503359C1	<b>COPLE DE 5.0"</b> RUBBER HUMP HOSE <b>500050</b>  OEM
SUSPENSIÓN:	SUSPENSIÓN:	SUSPENSIÓN:
ESPECIFICACIONES DE= 6.0" DS= 5.5" ÁNGULO= 45°	ESPECIFICACIONES DE= 4.0" DS= 4.0" L= 5.0"	ESPECIFICACIONES DE= 5.0" DS= 5.0" L= 5.0"

<b>COPLE DE 5.5"</b> RUBBER HUMP HOSE <b>550055</b>  OEM	<b>COPLE REDUCCIÓN DE 6.0" A 5.5"</b> RUBBER REDUCER HUMP HOSE <b>550060</b>  OEM	<b>COPLE DE 6.0"</b> RUBBER HUMP HOSE <b>600060</b>  OEM
SUSPENSIÓN:	SUSPENSIÓN:	SUSPENSIÓN:
ESPECIFICACIONES DE= 5.5" DS= 5.5" L= 6.0"	ESPECIFICACIONES DE= 5.5" DS= 6.0" L= 6.0"	ESPECIFICACIONES DE= 6.0" DS= 6.0" L= 5 1/4"

<b>COPLE DE 7.0"</b> RUBBER HUMP HOSE		<b>CORBATA PARA CABINA - CAMAROTE</b> RUBBER CAB SEAL		<b>CORBATA PARA CABINA - CAMAROTE</b> RUBBER CAB SEAL	
<b>700070</b>		<b>PBC-232</b>		<b>PBC-316</b>	
					
OEM		OEM K-097-C-1099		OEM K-097-1613	
SUSPENSIÓN:		SUSPENSIÓN: KENWORTH W-900		SUSPENSIÓN: KENWORTH T-800	
ESPECIFICACIONES DE= 7.0" DS= 7.0" L= 6 3/4"		ESPECIFICACIONES		ESPECIFICACIONES	

**PARBO** M.R.  
PARTES PARA SUSPENSION

*FOR A SMOOTH RIDE®*

# PARBO<sup>M.R.</sup>

PARTES PARA SUSPENSION

PARA UN MANEJO SUAVE\*



## PARTES PARA SUSPENSIÓN DE EQUIPO PESADO EN HULE Y POLIURETANO

RUBBER AND URETHANE  
HEAVY DUTY SUSPENSION PARTS



**FÁBRICA Y OFICINAS**  
**PARTES PARA BOMBAS, S.A. DE C.V.**  
BLVD. A ZACATECAS NO. 603  
FRACC. LAS HADAS  
APDO. POSTAL 3-38 C.P. 20140  
AGUASCALIENTES, AGS., MÉXICO

**CONMUTADOR Y FAX:**  
+52 (449) 914 24 22 / 912 21 51  
914 27 82 / 912 24 10  
912 02 88 / 912 24 43

**VENTAS FAX 01 800 265 PARBO (72726)**

**NEXTEL 52\*287611\*3**  
**SERVICIO A CLIENTES EXT. 116 Y 111**  
ventas@parbo.com.mx  
parboventas@prodigy.net.mx

**CENTRO DE DISTRIBUCIÓN MONTERREY**  
REFORMA NO. 1616 PTE.  
ZONA CENTRO C.P. 64000  
MONTERREY, N.L. MÉXICO  
**TELÉFONO: +52 (81) 8375 41 37**  
8375 41 38  
8375 41 39

**FAX: 8375 41 23**



CENTRO DE DISTRIBUCIÓN EN ESTADOS UNIDOS / U.S.A. DISTRIBUTION CENTER

Visítenos en / Visit us at [www.parbo.com.mx](http://www.parbo.com.mx)